

KIT MANUAL 2017 YZF-R1



**RACING
KIT PARTS**
YZFR116

YEC
RACING PARTS

Introduction

- This manual is intended for persons with knowledge and experience of motorcycles. Please refer to the YZF-R1 service manual, which shall be published from YAMAHA MOTOR CO. LTD., for information on part assembly and maintenance.
- The design of the YZF-R1 racing kit is based on YZF-R1, according to FIM racing rules, but that does not mean the kit conforms to all competitions. When used in races, riders must mount the YZF-R1 racing kit at their own discretion after checking the rules of competition issued by the sponsor.

About Warranty

- Please understand that these parts are not covered by warranty.
- The Manufacturer does not take any responsibility for problems caused by these parts.

Request

- These kit parts are intended exclusively for racing purposes. You are strictly requested not to use them on public roads.
- The specifications and usage methods of these kit parts along with the contents of this manual are subject to change without notice for improvement.

Parts List Symbols

- The star mark (*) means that the part is included in the kit set and is a genuine Yamaha part. Therefore, you can easily purchase the part at any Yamaha part dealer when necessary.
- The circle mark (°) means that although the part is included in the kit set it can also be purchased individually.

	No.	PART No.	PART NAME	Q'TY	REMARKS
°	1	4C8-11181-70	GASKET, CYLINDER HEAD 1	3	t=0.30mm
*	2	5VY-11351-00	GASKET, CYLINDER 1	3	
*	3	4C8-11603-00	PISTON RING SET	12	
	4	5VY-1165A-01	BOLT, CONNECTING ROD SPECIAL	24	
*				24	

Symbol Marks

Particularly important information is distinguished in this manual by the following notations.



This is the safety alert symbol. It is used to alert you to potential personal injury hazards. Obey all safety messages that follow this symbol to avoid possible injury or death.



A WARNING indicates a hazardous situation which, if not avoided, could result in death or serious injury.



A NOTICE indicates special precautions that must be taken to avoid damage to the vehicle or other property.



A TIP provides key information to make procedures easier or clearer.

CONTENTS

1 Engine Specifications	1
2 Kit Parts.....	2
2-1 Installing Electrical Parts.....	2
1. ECU Set (2CR-8591A-72)	2
2. Cable Interface (2CR-8533A-70).....	4
3. Wire Harness Set (2CR-F2590-70).....	6
4. Headlight Harness Set (BX4-F4350-70).....	17
5. Repair set (BX4-28130-70, 2KS-28130-71)	18
6. CCU COMP. (2KS-85800-70)	19
2-2 Installing Engine Parts.....	24
7. Maintenance Set (2CR-MAINT-71).....	24
8. Spark Plug Set (14B-R465B-70)	25
9. Piston Set (2CR-116A0-71).....	26
10. Connecting Rod Set (2CR-1165B-70).....	26
11. Crankshaft (2CR-11400-71)	26
12. High-lift Camshafts, Cam Sprocket.....	28
13. Valve Spring Set (2CR-A2110-71)	30
14. Air Funnel Set (2CR-1440B-70).....	31
15. AIS-plug Set (2CR-A4890-70).....	32
16. Transmission Gear	33
17. Mission Maintenance Set (2CR-A7000-70).....	36
18. Drive Sprockets	39
19. Sprocket Nut Set (2CR-A7463-70)	40
20. Strainer Cover Set (2CR-13400-70)	41
2-3 Installing Chassis Parts	45
21. Spring Rear Shock.....	45
22. Spring Front Fork	46
23. Seat Cushion (13S-24713-70).....	48
24. Front Spare Wheel ASS'Y (2CR-25100-70)	49
25. Rear Spare Wheel ASS'Y (2CR-25300-70).....	50
26. Tube Guide (2CR-26243-70)	51
3 Tightening Torque List.....	52
Tightening the Cylinder Head	65
Installing the Crankcase	66
Procedure to tighten the aluminum bolts	67
When replacing aluminum bolts with iron bolts.....	68
Procedure to install the engine	69
Procedure to install the pivot shaft peripheral parts	70
4 Headlight Cord Wiring Diagram	71
5 YZF-R1 Wiring Diagram	72

1 Engine Specifications

Spec		SBK/JSB	STK	STD
Displacement		998cm ³	998cm ³	998cm ³
Bore/Stroke		79.0 × 50.9 mm	79.0 × 50.9 mm	79.0 × 50.9 mm
Maximum engine speed (limiter controlled speed)		14500 rpm	14500 rpm	14500 rpm
Compression ratio (recommended value)		13.0 – 13.4 Depending on head surface grinding	13.0	13.0
Valve timing (event angle)	INT	105°	108°	108°
	EXT	108°	110°	110°
Clearance between valve and piston (minimum)	INT	0.95 mm	–	–
	EXT	1.90 mm	–	–
Valve (tappet) clearance	INT	0.09 – 0.17 mm	0.09 – 0.17 mm	0.09 – 0.17 mm
	EXT	0.18 – 0.23 mm	0.18 – 0.23 mm	0.18 – 0.23 mm

2 Kit Parts

2-1 Installing Electrical Parts

1. ECU Set (2CR-8591A-72)

Parts List

No.	PART No.	PART NAME	Q'TY	REMARKS
1	2CR-8591A-72	ECU	1	
2	2CR-2818Y-73	CD	1	YMS SOFT & MANUAL '17 Ver.

- Use of this set and a wire harness included in the kit enables regulation (or setting) of fuel injection and ignition timing, etc.
- For details as to how to regulate (or set) fuel injection and ignition timings, etc., refer to the FI matching system manual in the CD-ROM that comes with the set.
- There are two types of basic control data for the ECU included in this set: SB (Super Bike) and ST (Stock Sports). They can be switched over and vice versa. To make it in the ST specification, just remove two couplers located at the lower left of the kit harness fuel tank.

(See the figure below.)

<Setting-up Details>

SB specification: Kit cam shaft, Kit valve spring, Kit air funnel set, *Recommended muffler

ST specification: *Recommended muffler

* Recommended muffler

Made by Akrapovic (For details of the specification, please access the website.)

Web <http://www.akrapovic-exhaust.com/>

NOTICE

Before using the KIT ECU for the first time, use YMS to perform writing of the base map.

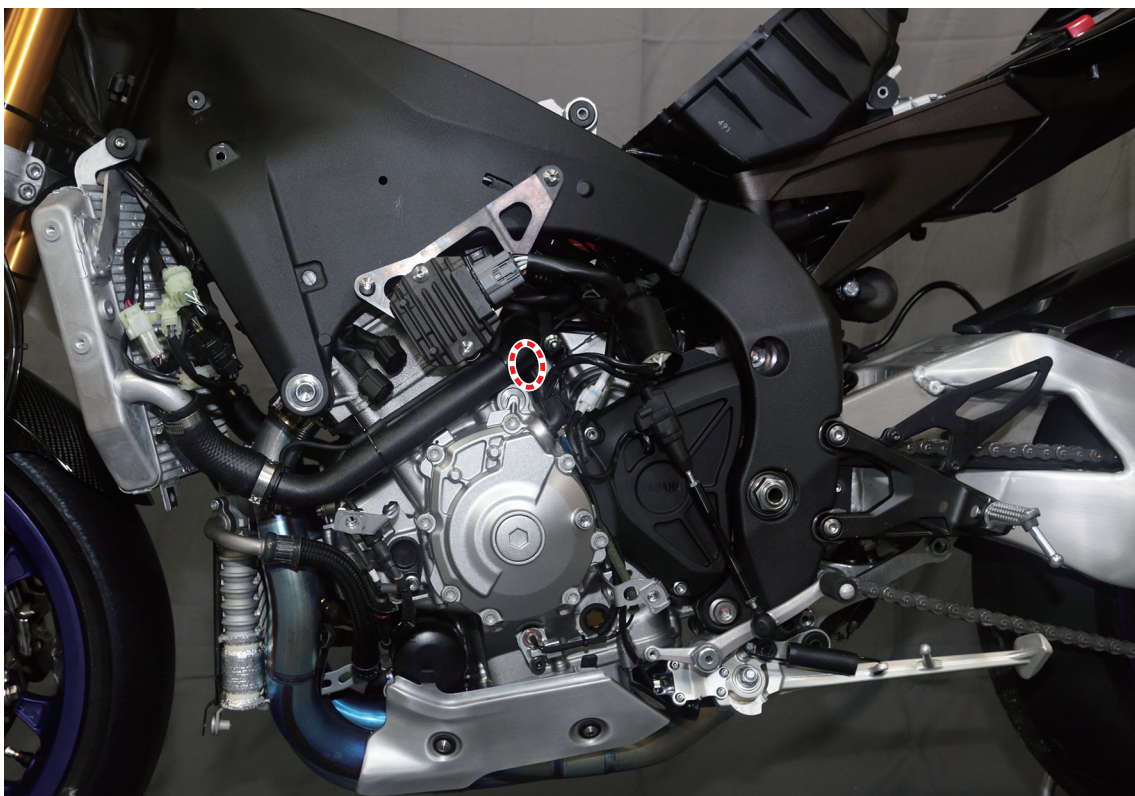

The set of the camshaft, valve spring, ECU and air funnel must be used in the following combination.

MODEL	CAMSHAFT (IN)	CAMSHAFT (EX)	VALVE SPRING	ECU	AIR FUNNEL SET
2015	2CR-12170-70	2CR-12180-70	2CR-A2110-70	2CR-8591A-70	MGC-191114-00
2016			2CR-A2110-71	2CR-8591A-71	2CR-1440B-70
2017			2CR-A2110-71	2CR-8591A-72	

NOTICE

Using in other combinations may possibly damage the engine.

Be sure to use in the combination as stated above.

2. Cable Interface (2CR-8533A-70)

Parts List

No.	PART No.	PART NAME	Q'TY	REMARKS
1	2CR-8533A-70	CABLE, INTERFACE	1	USB
2	2CR-N81CD-70	CD	1	USB driver Windows 8 supported

- This cable connects the kit wire harness to the personal computer on which YEC FI Matching System (YMS) is installed.
- Please see the YMS manual for instructions on how to use YMS.
- When connecting the cable to the PC for the first time, it is necessary to install the USB driver. Refer to the USB Driver Installation Manual provided on the CD for details on how to install the USB driver.

Diagnosis Functions

- Use of the ECU in the kit and the harness allows functioning of the following codes in the STD diagnosis.

CODE	Contents
01	Throttle position sensor signal 1
02	Atmospheric pressure
03	Intake air pressure
05	Air temperature
06	Coolant temperature
07	Rear vehicle speed pulse
09	Fuel system voltage (battery voltage)
13	Throttle position sensor signal 2
14	Accelerator position sensor signal 1
15	Accelerator position sensor signal 2
16	Front vehicle speed pulse
17	Bank angle
20	Pit road limiter
21	YMS MAP SW.
30	Ignition coil #1
31	Ignition coil #2
32	Ignition coil #3
33	Ignition coil #4
34	Intake funnel
36	Injector (primary) #1

CODE	Contents
37	Injector (primary) #2
38	Injector (primary) #3
39	Injector (primary) #4
40	Injector (secondary) #1
41	Injector (secondary) #2
42	Injector (secondary) #3
43	Injector (secondary) #4
47	Steering damper solenoid
48	AIS
49	Intake solenoid
50	Main relay
51	Radiator fan
52	Headlight
60	EEPROM
61	Content confirmation
62	Content confirmation
63	Content confirmation
67	ISU
70	Program number
86	Shift switch

Self-Diagnosis Functions

The ECU is equipped with a self-diagnostic function in order to ensure that the fuel injection system is operating normally. If this function detects a malfunction in the system, it immediately operates the engine under substitute characteristics and illuminates the engine trouble warning light to alert the rider that a malfunction has occurred in the system. Once a malfunction has been detected, a fault code is stored in the memory of the ECU.

(* For information about the deletion method, see 2CR/BX4 STD Service Manual.)

- To inform the rider that the fuel injection system is not functioning, the engine trouble warning light flashes when the start switch is being pushed to start the engine.
- If the self-diagnosis function detects a malfunction in the system, the ECU performs an appropriate substitute operation and illuminates the engine trouble warning light (diagram "1"), and the fault code number (diagram "2") is displayed.

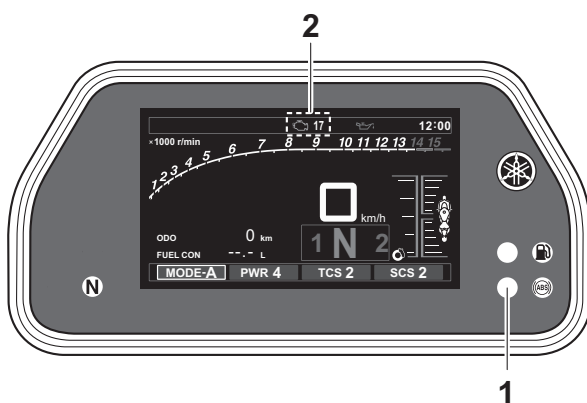

- The ECU and harness in the kit provide the functions for the following codes of standard self-diagnosis:

CODE	Description
8	Gear position sensor malfunctions
11	Cam angle sensor malfunctions
12	Cylinder angle sensor malfunctions
13	Intake pressure sensor malfunctions (open circuit / short circuit)

CODE	Description
14	Intake pressure sensor malfunctions (piping system)
15	Throttle opening sensor malfunctions (open circuit / short circuit / ETV)
20	Intake pressure sensor or atmospheric pressure sensor malfunctions
21	Water temperature sensor malfunctions (open circuit / short circuit)
22	Intake temperature sensor malfunctions (open circuit / short circuit)
23	Atmospheric pressure sensor malfunctions (open circuit / short circuit)
33	Ignition coil #1 malfunctions (open circuit)
34	Ignition coil #2 malfunctions (open circuit)
35	Ignition coil #3 malfunctions (open circuit)
36	Ignition coil #4 malfunctions (open circuit)
39	Injector (primary) malfunctions (open circuit)
40	Injector (secondary) malfunctions (open circuit)
42	Rear wheel sensor malfunctions
43	Battery voltage monitor malfunctions (power source for fuel system)
44	EEPROM malfunctions
45	ECU malfunctions (electrical power system)
46	Power source for vehicle malfunctions
50	ECU malfunctions (main unit)
59	Accelerator opening sensor malfunctions (open circuit / short circuit)
60	Throttle motor malfunctions (drive system)
69	Front wheel sensor malfunctions
70	Engine stop by idling away
98	IMU malfunctions (main unit)
99	IMU malfunctions (communication system)

3. Wire Harness Set (2CR-F2590-70)

Parts List

No.	PART No.	PART NAME	Q'TY	REMARKS	
1	2CR-82590-70	WIRE HARNESS ASSY.	1	MAIN HARNESS	
°	2	2CR-82386-70	WIRE,SUB-LEAD for TH INJECTOR	1	TH INJECTOR
°	3	2CR-82318-70	WIRE,SUB-LEAD for AC INJECTOR	1	AC INJECTOR
°	4	2CR-82309-70	WIRE,SUB-LEAD for IG. COIL	1	IGNITION COIL
°	5	2CR-8231Y-70	WIRE,LEAD for FUEL PUMP	1	FUEL PUMP
°	6	2CR-83553-70	WIRE,LEAD for METER	1	METER
	7	2CR-2128A-70	BRKT., REGULATOR 1	1	
*	8	90480-13003	GROMMET	2	
*	9	90560-06201	SPACER	2	
*	10	90111-06051	BOLT, HEX. SOCKET BUTTON	2	
*	11	95607-06200	NUT, U FLANGE	2	
	12	2CR-2161E-70	BRKT.,4	1	
*	13	90338-06018	PLUG	3	
*	14	120-82131-00	BAND, BATTERY	1	
*	15	90111-06051	BOLT, HEX. SOCKET BUTTON	1	
	16	2CR-2161G-70	BRKT.,6	1	
*	17	14B-8183G-01	CORD COMP.	1	

This wire harness is weight-saved by doing away with connecting wires for lights.

WIRE, SUB-LEAD

Parts List

No.	PART No.	PART NAME	Q'TY	REMARKS
20	2KS-82509-70	WIRE, SUB-LEAD	1	SCU

This wire harness is for mounting the KIT harness to a vehicle with the Electric racing suspension (ERS) function.

TIP

If the E-SD (STD steering damper) is not used, removing its coupler will pose no problem.

NOTICE

- Before using the KIT ECU for the first time, use YMS to perform writing of the base map.
- Remove the coupler of the main switch before starting assembling work.

NOTICE

- Do not remove the AC generator but leave it to function. Use on the battery alone will make the machine unable to run in a short time.
- This wire harness only works when used in combination with the ECU (2CR-8591A-70, 71, 72) of the kit.
- Using the KIT ECU disables the ABS function of the brake, but do not remove the Hydraulic unit assy. and connect it to the wire harness of the kit. Without this connection, any computerized controls will not work.

Installing Wire Harness:

1. Remove the STD wire harness from the chassis.
2. Cut the shaded area off the battery box (to provide an installation area for fixing for BRKT.,4 ⑫ seat).

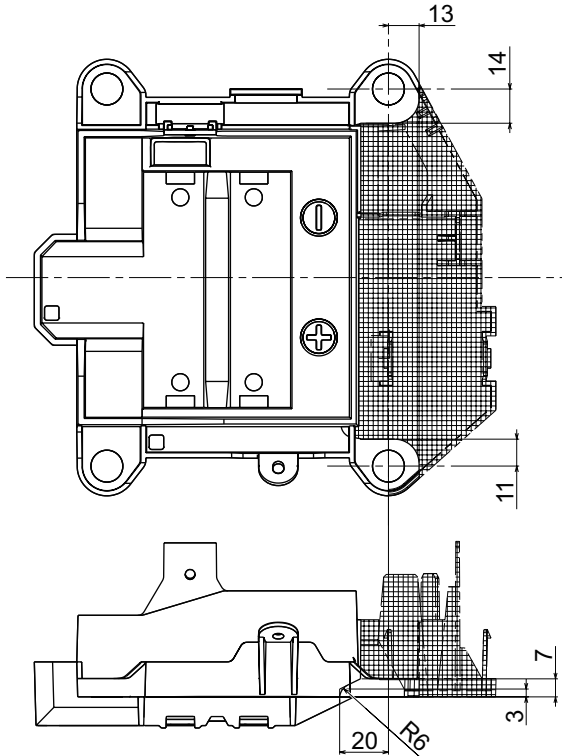

3. Install PLUG ⑬ to BRKT.,4 ⑫.
By using the STD battery box installation bolt and bolt ⑮, install BRKT.,4 ⑫ to the shaped battery box.
Pass band ⑭ through BRKT.,6 ⑯.
Secure the ECU with band ⑭.
Install the relay ASSY. and main fuse to and BRKT.,6 ⑯.

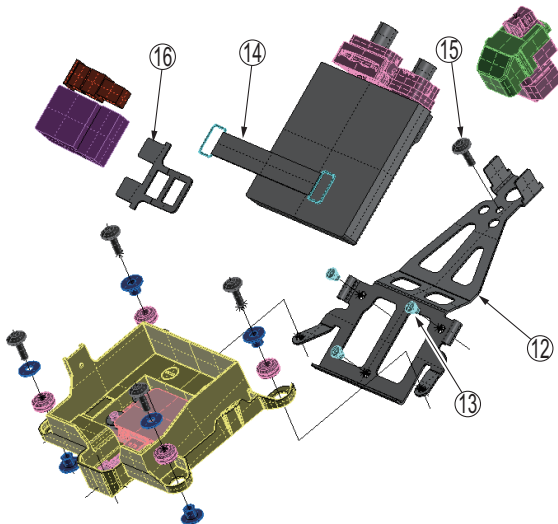

- Cut the shaded area off the LH side cover (to provide an installation area for sixing for BRKT., REGULATOR 1 ⑦ seat).

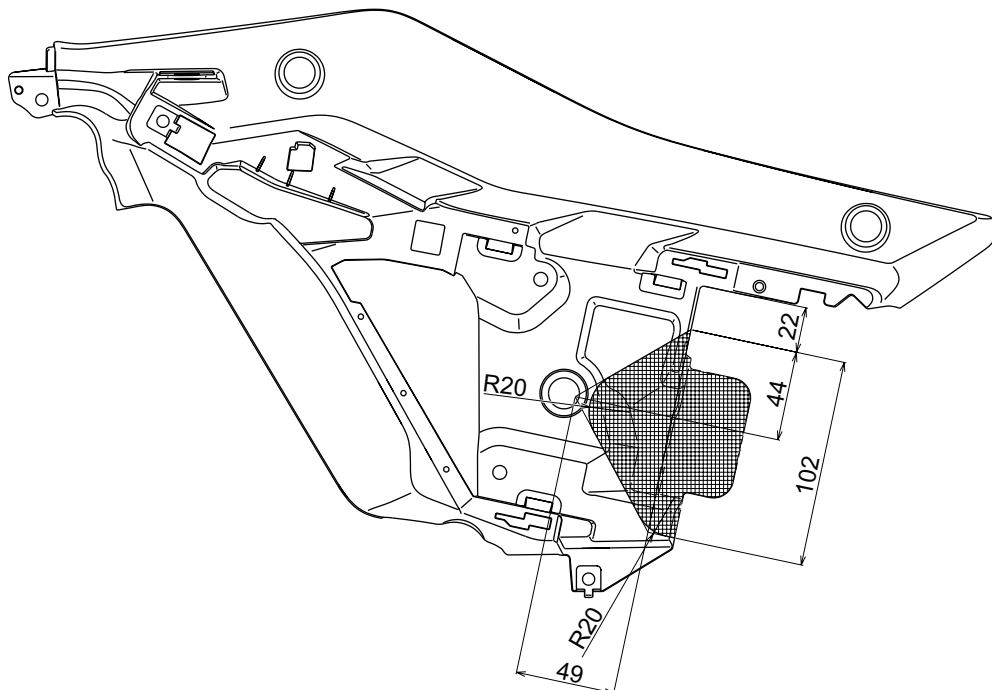

- Remove from the chassis the STD rectifier/regulator that is installed on the right side of the radiator. Install the rectifier/regulator using the bracket, regulator ⑦, grommets ⑧, spacers ⑨, bolts ⑩ and nuts ⑪. Face the bracket and regulator ⑦ inward and tighten them together with the shaped side cover.

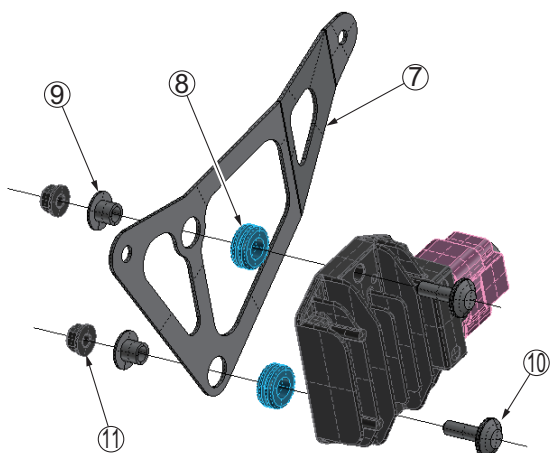

- Replace the STD CORD COMP. (starter motor lead wire) with the CORD COMP. ⑰.

7. Install the wire harness of the kit as the diagram.

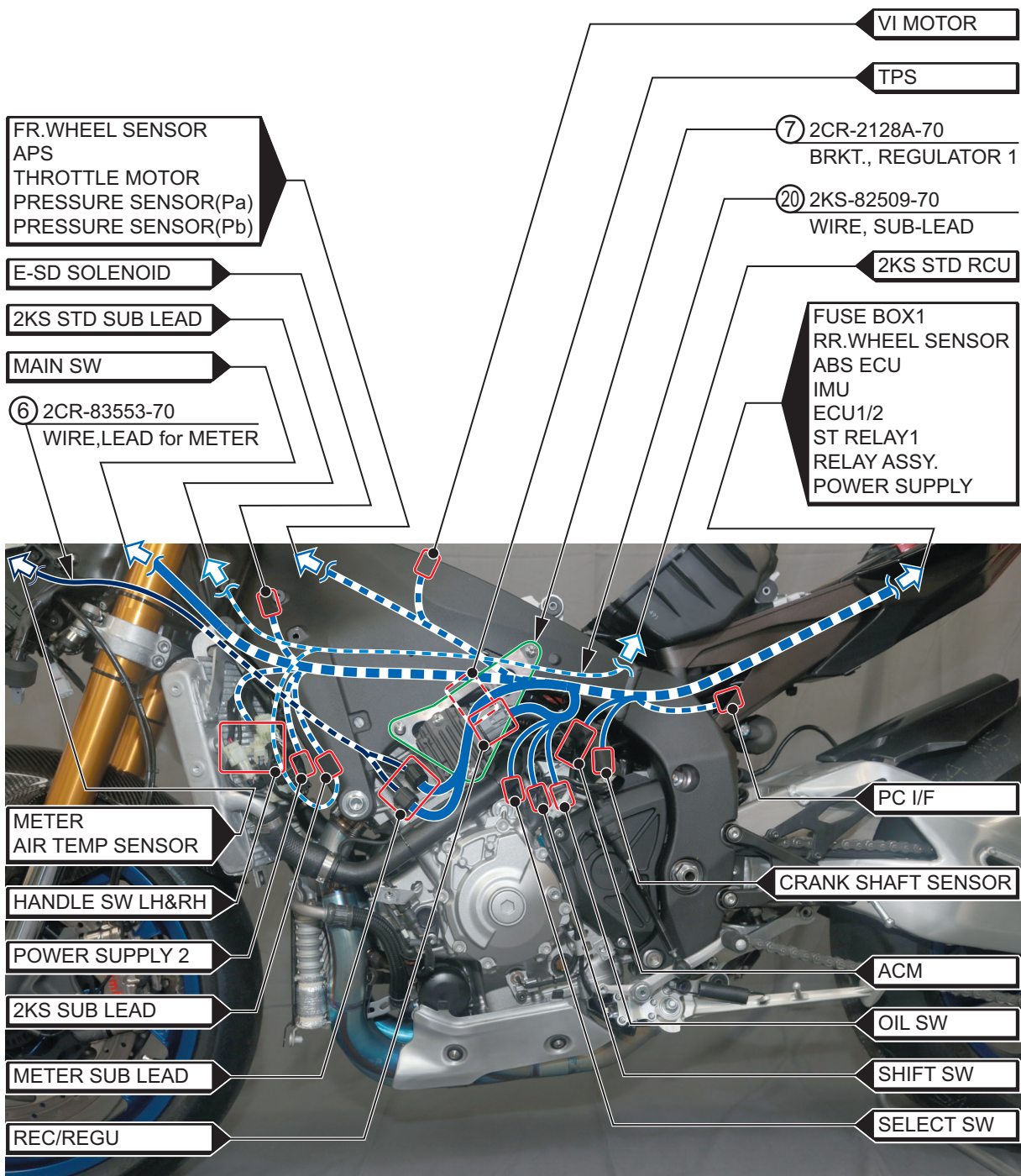

▢ → , ← ▢ indicate the names of parts to be connected.

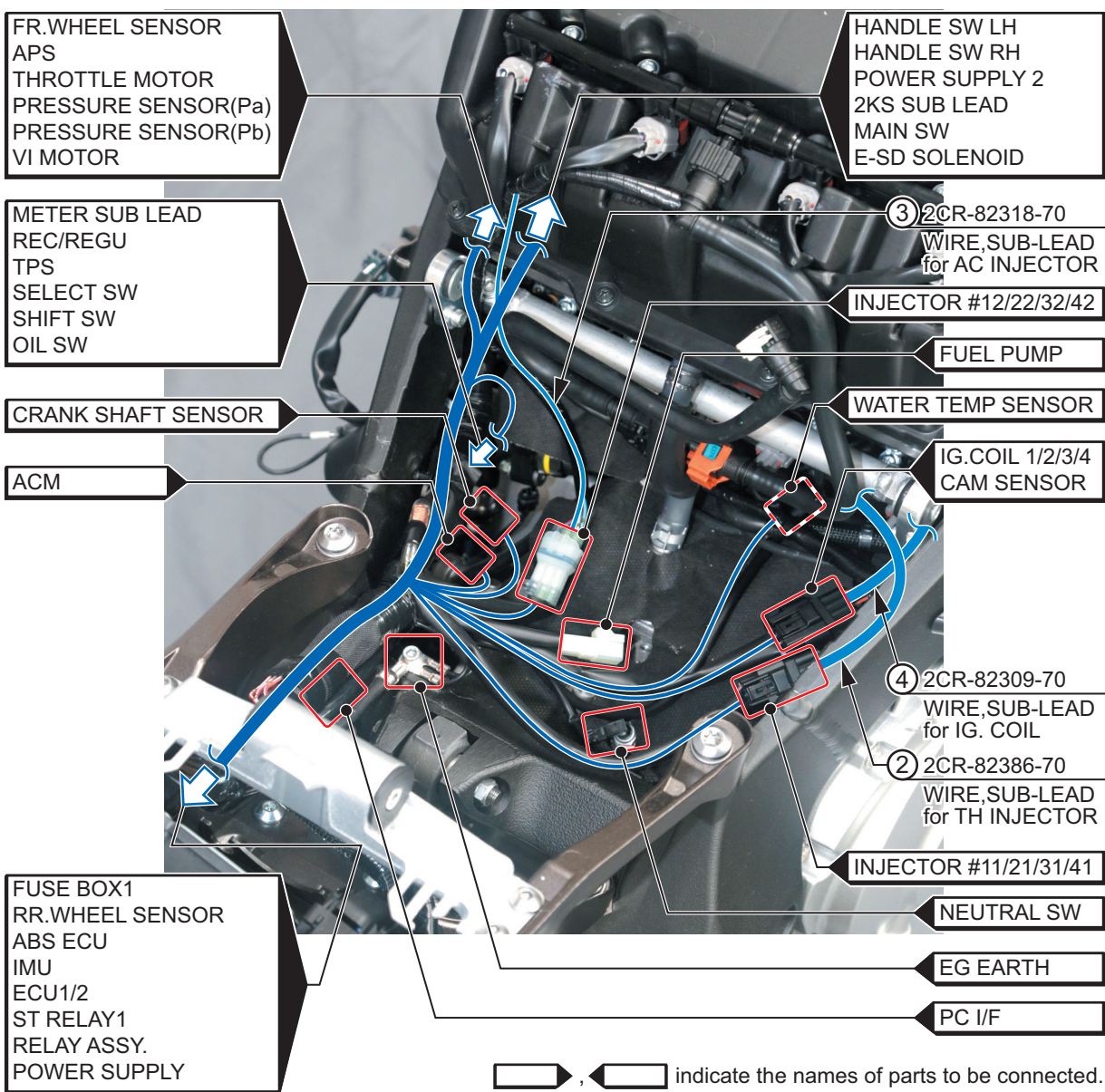
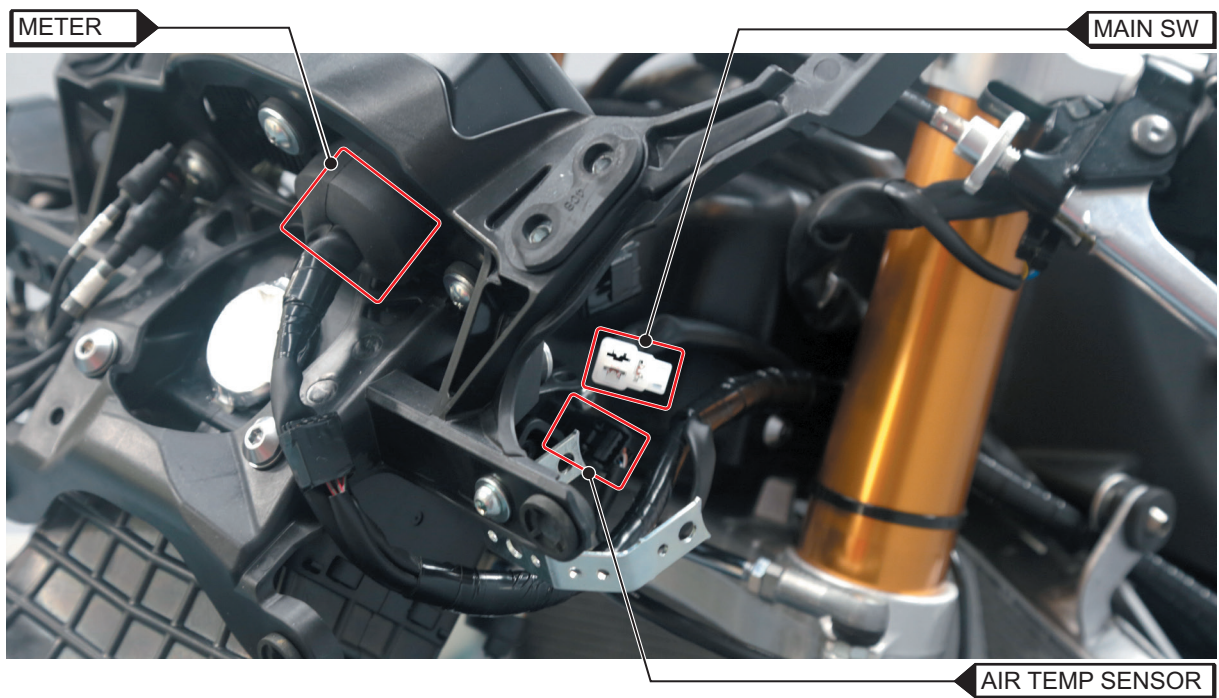

indicate the names of parts to be connected.

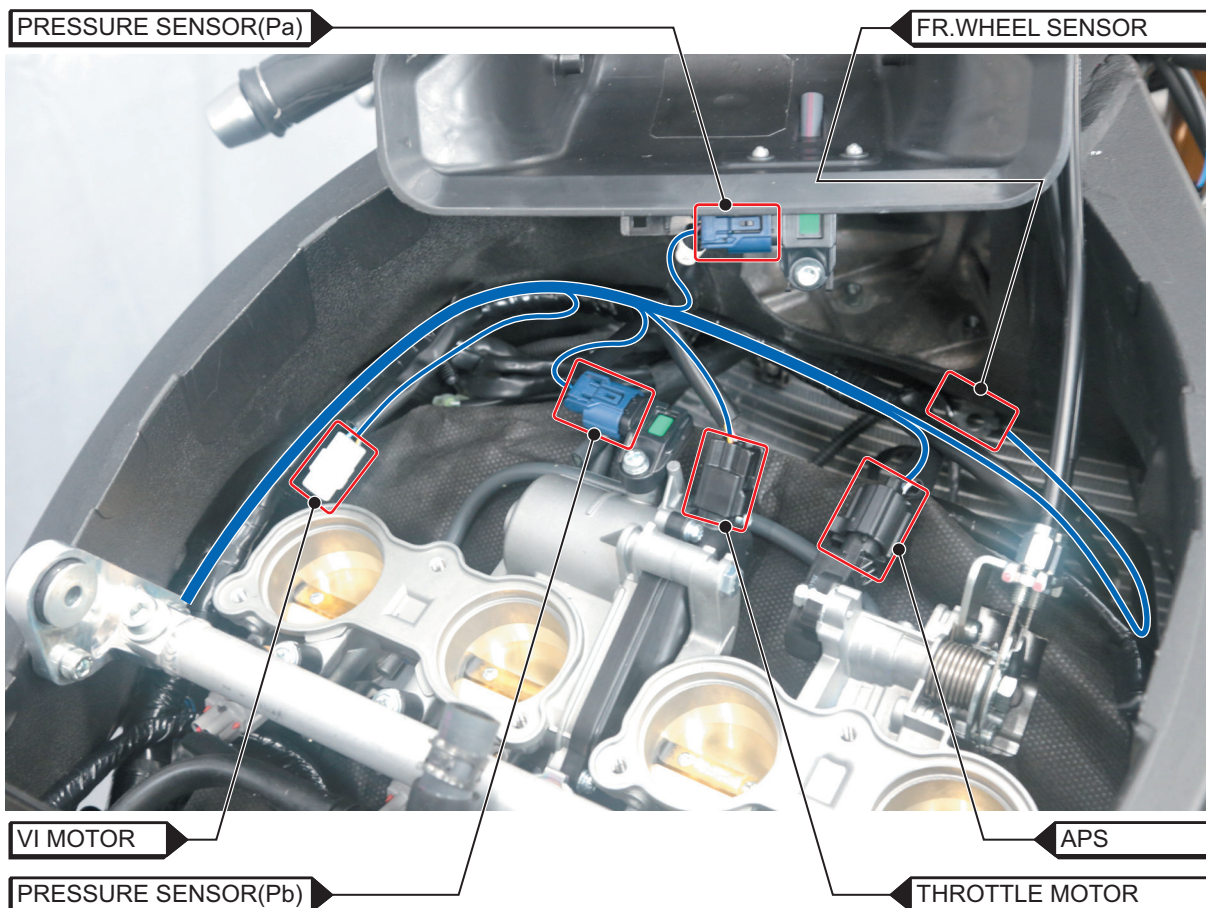

▶ , ◀ indicate the names of parts to be connected.

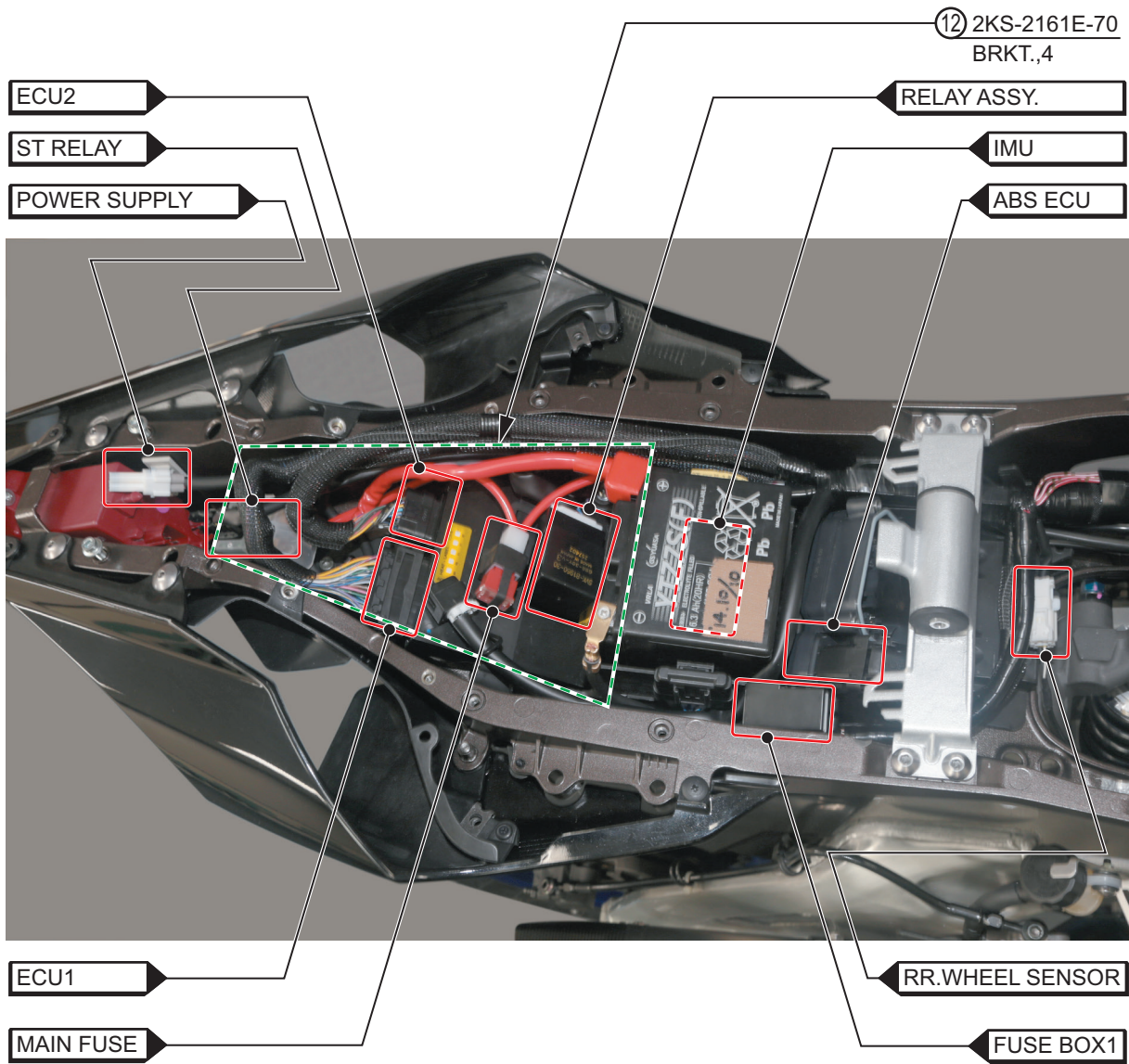

□, □ indicate the names of parts to be connected.

The name and function of each switch

<Left>

Keep the switch at low position
 Hi position→the LAP switch becomes non-functional

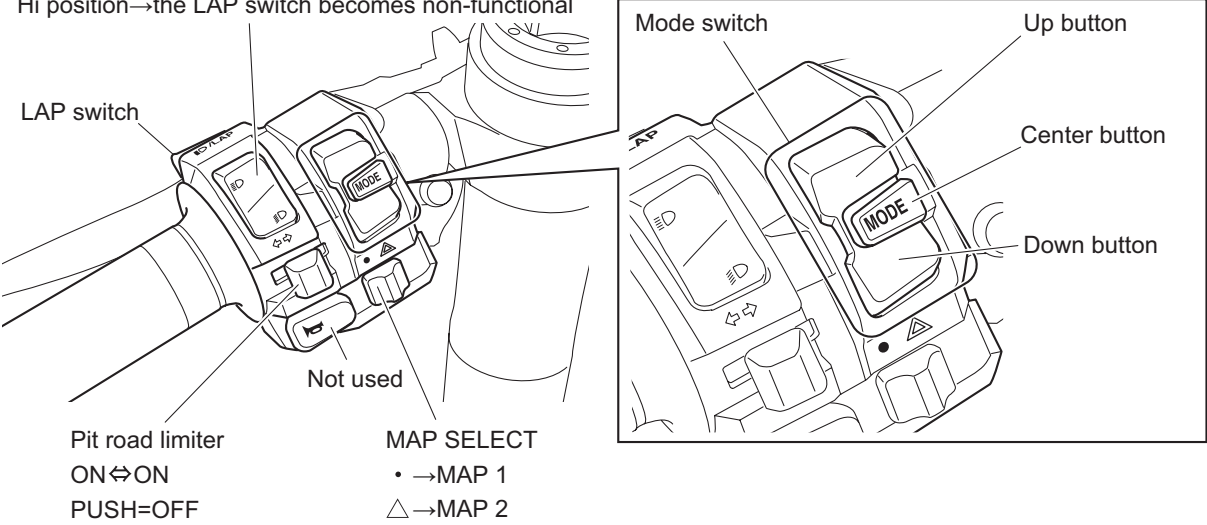

<Right>

Starter switch/Engine stop switch

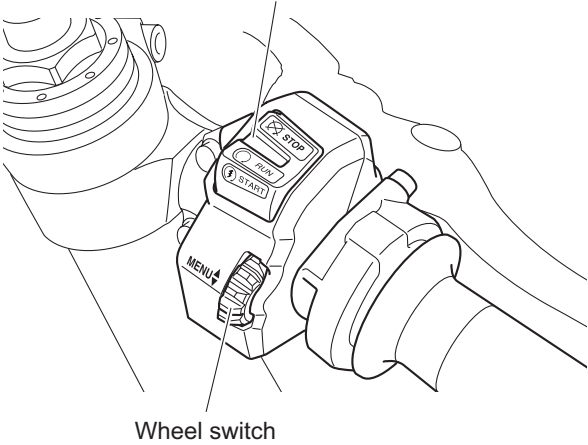

YRC : Yamaha Ride Control

Yamaha Ride Control is a system that controls the engine output based on data received from the sensors and IMU.

The functions listed below represent individual YRC items which can be turned on/off or adjusted to suit various riders and riding conditions.

For details on the settings, see “MENU” in the Owner’s Manual.

* The meter MENU screen cannot be displayed if “T.TRIP” is selected when the battery or meter is reconnected.

IMU : Inertial Measurement Unit

PWR : Power Delivery Mode

TCS : Spin control system

SCS : Slide control system

LCS : Launch control system

QSS : Quick shift system

LIF : Lift control system

ERS : Electric racing suspension by ÖHLINS
(available only with 2KS)

IMU : Inertial Measurement Unit

IMU is 6-axis inertial measurement unit. It consists of three gyro sensors (angular sensors) that measure a: machine pitch, b: roll, and c: yaw, and three G-sensors (accelerometer) that measure acceleration in the forward-backward, up-down and right-left directions. YRC controls the engine output based on data received from those sensors.

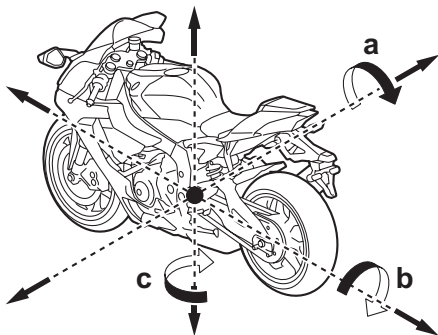

TIP

If the installation position or angle of the inertial measurement unit is changed, YRC does not function properly because measurements are not available.

PWR : Power Delivery Mode

The power mode selection system consists of four different control maps to regulate throttle valve opening depending on the degree of throttle opening, thus providing the rider with a selection of modes to fit rider’s preferences and the riding environment.

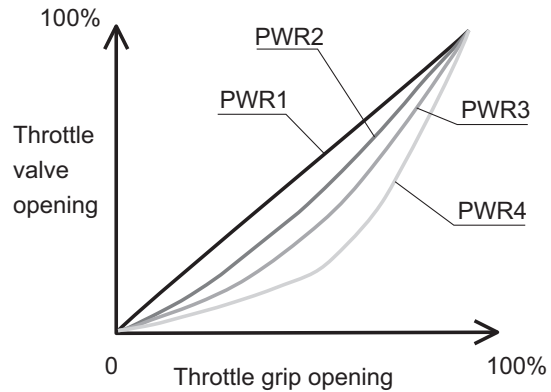

TCS : Spin control system

The spin control system helps maintain traction when accelerating. If sensors detect that the rear wheel is starting to slip (uncontrolled spinning), the spin control system assists by regulating engine power as needed until traction is restored.

This system supports the SCS to contribute to a smoother ride.

The TCS-1 effect becomes 0.

If TCS is set to “OFF”, SCS, LCS, QSS and LIF are also set to OFF automatically.

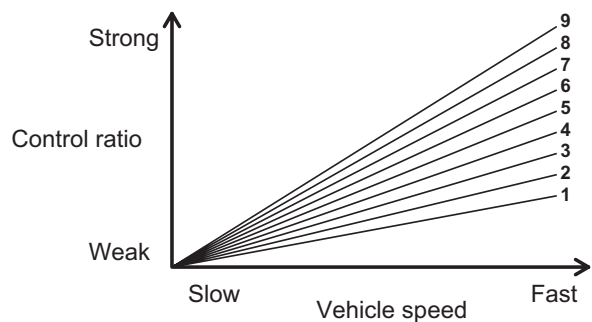

SCS : Slide control system

The slide control system controls engine power output when a sideward slide is detected in the rear wheel.

It adjusts output to an optimum level based on data from the IMU, thus helping the rider focus on riding without distraction.

This system supports the TCS to contribute to a smoother ride.

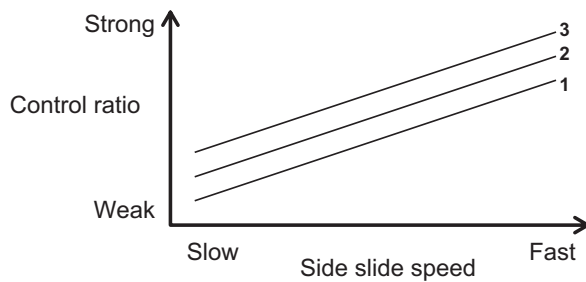

LCS : Launch control system

The launch control system helps ensure smooth and swift starts.

The LCS maintains an optimum level of engine output in conjunction with input from the TCS and LIF systems even with the throttle fully open.

This allows the rider to concentrate on clutch engagement and vehicle control to reduce stress during starts.

LCS works in conjunction with TCS and LIF systems.

If TCS is set to "OFF", LIF is also set to OFF automatically.

QSS : Quick shift system

The quick shift system provides speedy, full-throttle upshifts.

LIF : Lift control system

The lift control system reducing wheel lift rate during extreme acceleration, such as during starts or out-of-corner acceleration.

When front-wheel lift is detected by the IMU, engine output is adjusted to the optimum level to compensate for it and thus assist the rider's vehicle control.

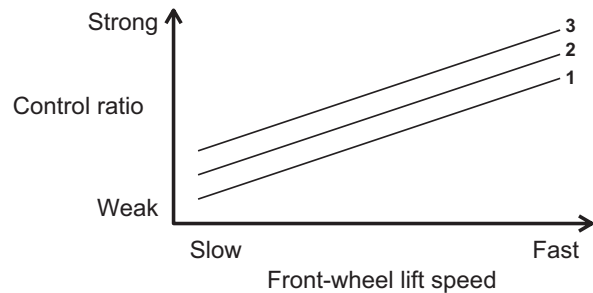

ERS : Electronic racing suspension

The Ohlins electronic racing suspension takes data from the IMU and the suspension control unit (SCU) makes integrated adjustments of both the front and rear suspension's damping force based on running conditions.

About the front and rear wheel speed sensor

Do not remove the speed sensors installed at the front and rear wheels because they are used for regulating YRC controls.

- If you change the front and rear wheels to non-standard parts, manufacture and attach a rotor and sensor referring to the diagram below.
 - If you change the front fork/rear brake bracket to a non-standard part too, create a mount for the sensor assembly and attach the front and rear wheel sensors referring to the diagram below.
- *1. When manufacturing a rotor and sensor, use a steel type material with magnetic properties.
 - *2. Make the angle of attachment in the rotation direction of the rotor of the sensor assembly the same as the angle indicated in the diagram below.
 - *3. If you change the rotor sensor or sensor assembly attachment bracket to a non-standard part, there is a possibility of malfunction due to vibration or noise even if the part is attached properly.

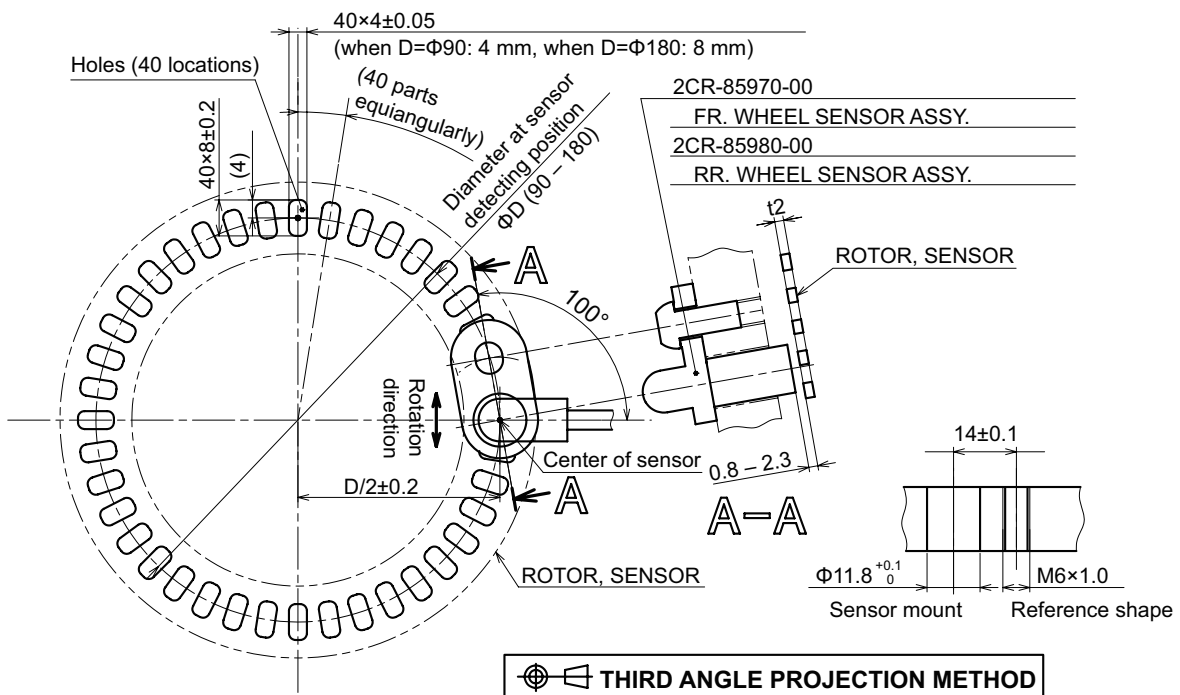

4. Headlight Harness Set (BX4-F4350-70)

Parts List

No.	PART No.	PART NAME	Q'TY	REMARKS
1	BX4-84359-70	CORD, HEAD LIGHT	1	
*	5GF-83976-00	SW., HANDLE 1	3	Light ON/OFF SW. x 2 Emergency SW.

This set is used in endurance races in combination with the kit harness for turning on the STD headlights and taillights.

It assumes that the standard headlights and taillights are used.

There are three light switches.

SW.1 : Turns on the headlight (high beam) and taillight 1

SW.2 : Turns on the headlight (low beam) and taillight 2

EMERGENCY SW. : Turns on the emergency light

Use the appropriate light according to the racing rules of the endurance race.

(Diagram)

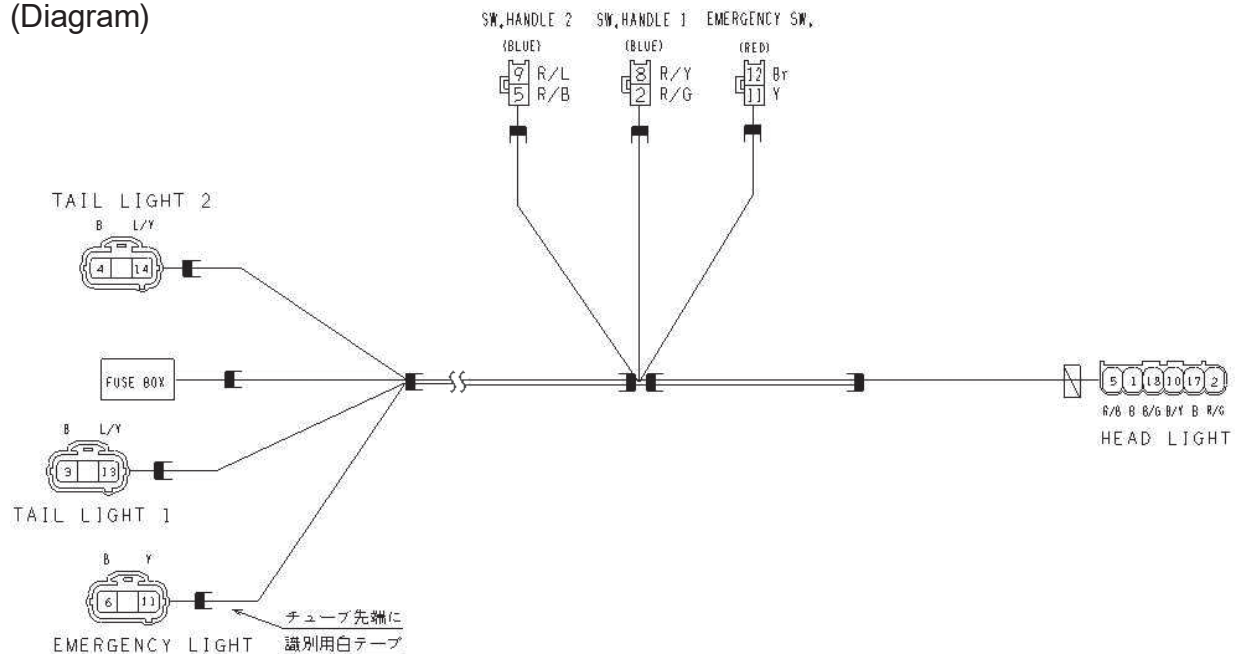

5. Repair set (BX4-28130-70, 2KS-28130-71)

Select the part set corresponding to your model.

Parts List

BX4-28130-70

	No.	PART No.	PART NAME	Q'TY	REMARKS
*	1	BX4-83500-00	METER ASSY.	1	
*	2	2CR-83963-00	SWITCH HANDLE 3	1	
*	3	2CR-83969-00	SWITCH HANDLE 5	1	
*	4	2CR-85970-00	FR. WHEEL SENSOR	1	
*	5	2CR-85980-00	RR. WHEEL SENSOR	1	

Parts List

2KS-28130-71

	No.	PART No.	PART NAME	Q'TY	REMARKS
*	1	2KS-83500-30	METER ASSY.	1	
*	2	2CR-83963-00	SWITCH HANDLE 3	1	
*	3	2CR-83969-00	SWITCH HANDLE 5	1	
*	4	2CR-85970-00	FR. WHEEL SENSOR	1	
*	5	2CR-85980-00	RR. WHEEL SENSOR	1	

6. CCU COMP. (2KS-85800-70)

The CCU (Communication control unit) facilitates checking or settings of the vehicle information, and enhances rider's relationship with the vehicle.

The CCU COMP. consists of the CCU ASSY. and GPS unit.

Download the application onto the tablet before use.

The CCU of YEC RACING PARTS is equipped with the general-purpose analog voltage (0 to 5 V) interface.

For information about the standard features, refer to the OWNER'S MANUAL for the vehicle or the explanation of the store application in addition to this manual.



Parts List

No.	PART No.	PART NAME	Q'TY	REMARKS
1	2KS-85810-70	CCU ASSY.	1	dedicated software embedded
*	2KS-88107-00	GPS unit	1	
3	2KS-85721-70	Sub-harness	1	
		Application		Download from App Store/Google Play Store

Components

CCU ASSY.

(dedicated software embedded)



GPS unit



Sub-harness



Application

Download from App Store/Google Play Store

TIP

The functions of the CCU unit

- Data logging (GPS positioning information, vehicle information, analog voltage)
- Line passing detection
- Wireless LAN main unit (IEEE 802.11b/g/n)

Preparation

- Install the units to the vehicle.

TIP

The gray and black cable is for AIN-1 (analog Ch1), and the purple and black cable is for AIN-2 (analog Ch2).

TIP

Since the eight-digit number (S/N:) on the CCU unit will be used as the password for wireless LAN connection between the tablet and CCU, be sure to write down the number.



TIP

When using it for the first time, check if the GPS icon lights up on the meter before riding.

(It may take about 10 minutes for GPS positioning even in an outdoor location.)

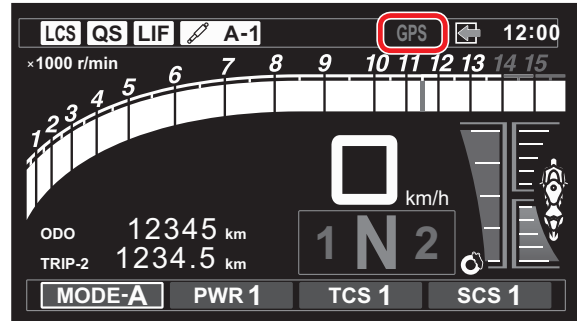

Since the GPS and oil-pressure warning icons are at the same location, the GPS icon does not light up when the the oil-pressure warning icon lights up (such as engine stop).

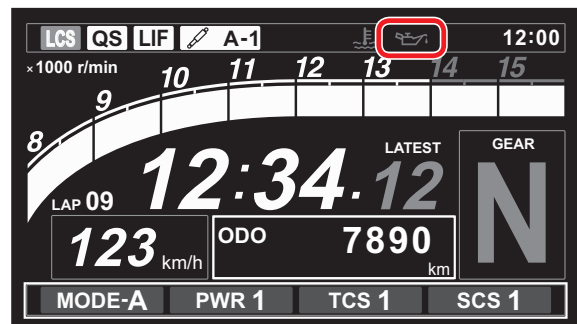

NOTICE

If GPS positioning is not available, it will affect functioning of logging.

- Download the application onto the tablet.

TIP

For Android, visit Google Play Store and download "Y-TRAC" and "CCU Config".



For iOS, visit App Store and download "Y-TRAC". (Y-TRAC is equipped with the CCU Config feature.)



In this manual, iOS version screens are used as examples.

Usage

	Operations on the tablet	Application to be used	Network to be connected
Before riding	Draw a circuit record line on the map. (See Fig. 1.)	CCU Config (Y-TRAC for iOS version)	Internet
	Transfer the record line to the CCU.	CCU Config (Y-TRAC for iOS version)	CCU
	Set the logging mode of the CCU to "Track". (See Fig. 2.)	CCU Config (Y-TRAC for iOS version)	CCU
While riding			
After riding	Download the logging data from the CCU.	Y-TRAC	CCU
	Display the logging data (with map).	Y-TRAC	Internet

(Fig. 1.)

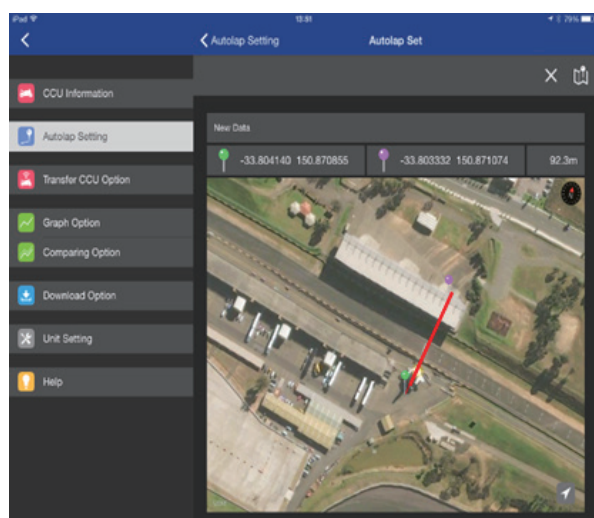

(Fig. 2.)

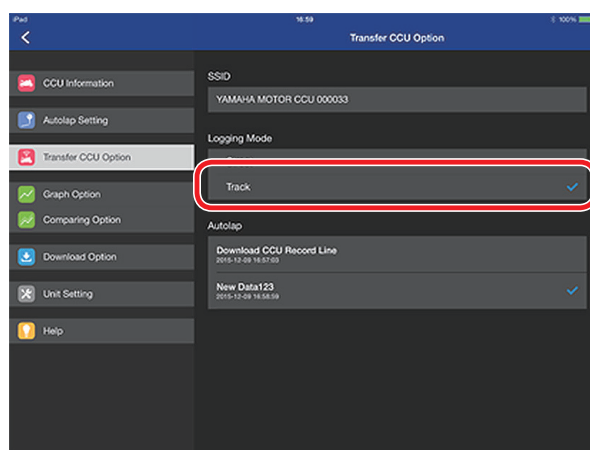

TIP

When connecting the tablet to the network, select CCU (when communicating with the CCU) or Internet (when displaying the map) according to the use.

Connecting to the CCU

Connecting to the CCU		Label on the CCU (See Fig.3.)
Network name (SSID)	YAMAHA MOTOR CCU ddeeff	MAC: aa-bb-cc-dd-ee-ff
Password	12345678	S/N: 12345678

(Fig. 3.)



TIP

When viewing logging data, analog Ch is not displayed by Y-TRAC default setting. To display it, tap Graph Setting in the Graph Option mode.

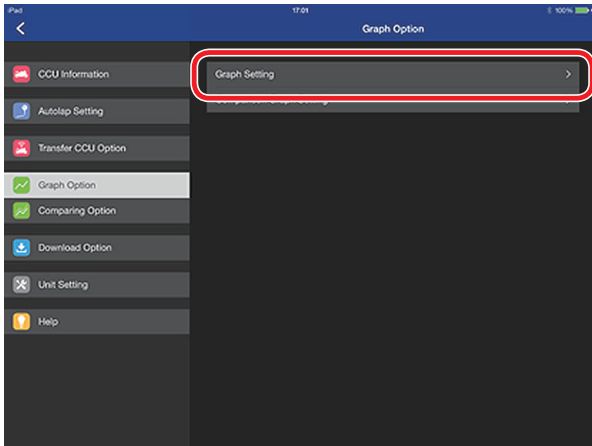

On the screen, tap AIN-1 or AIN-2 to display the arbitrary CH.

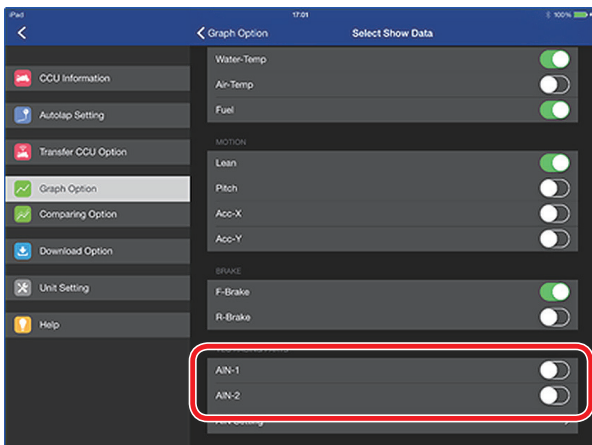

In the analog display mode, the voltage is indicated by level (0 to 5) by default. The display value can be changed according to the specification of the installed sensor. To change the display value, tap AIN Setting.

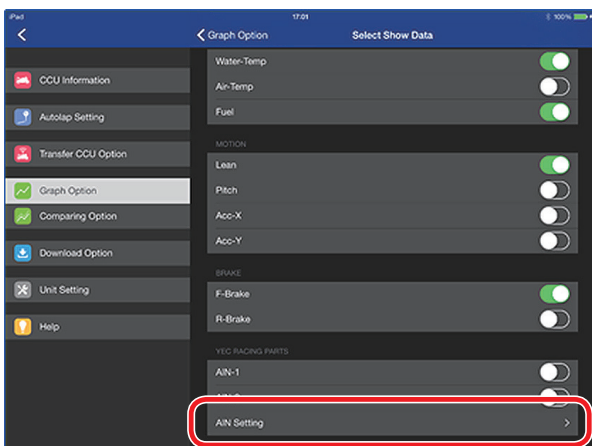

<Example 1>

When the following is stated in the sensor's manual

"AF value: voltage x 1.6 +10"

Factor 1.6000

Offset 10.0000

Min Y-axis 10.00

Max Y-axis 20.00

(Min Y-axis and Max Y-axis can be any given values)

<Example 2>

When the following is stated in the sensor's homepage

"Output voltage is three times the λ value."



AF value: output voltage x 14.7 / 3

Factor 4.9000

Offset 0.0000

Min Y-axis 10.00

Max Y-axis 20.00

(Min Y-axis and Max Y-axis can be any given values)

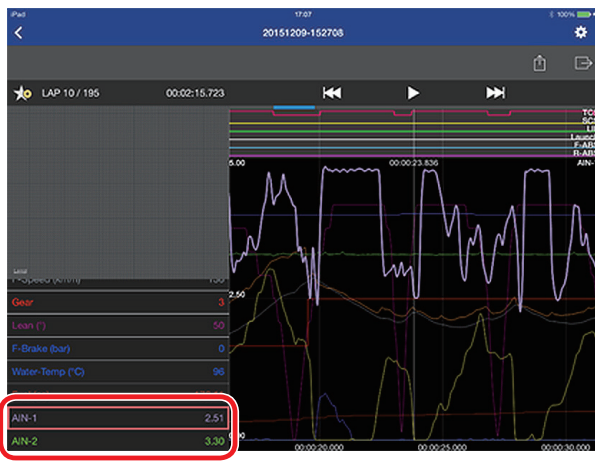
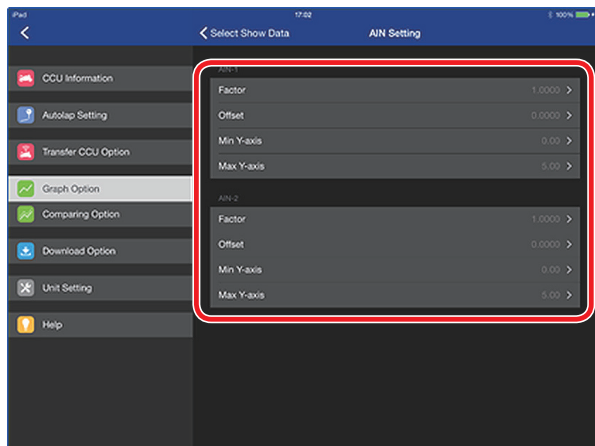

Other usages

Meter setting

To indicate CCU's detection of line passing on the meter, enable the stop watch function on the meter (blink ":" (column) and "." (period) in area 2).

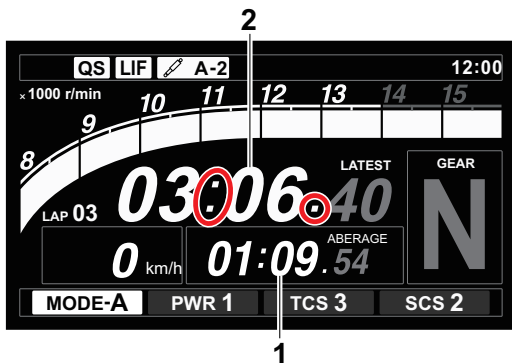

<Wheel switch operation procedure>

Press the wheel switch to blink area 1.



Rotate the wheel switch to blink area 2.



Press and hold the wheel switch to blink only ":" (column) and "." (period) in area 2.

This operation is required each time after the main switch is set to ON.

TIP

Regardless of the meter setting, lap data will be recorded in the logging data when line passing is detected,

2-2 Installing Engine Parts

7. Maintenance Set (2CR-MAINT-71)

Parts List

	No.	PART No.	PART NAME	Q'TY	REMARKS
*	1	2CR-11181-00	GASKET, CYLINDER HEAD 1	3	t=0.20 mm (STD)
*	2	2CR-11351-00	GASKET, CYLINDER 1	3	t=0.20 mm (STD)
*	3	2CR-11603-10	PISTON RING SET	12	
*	4	2CR-1165A-00	BOLT, CONNECTING ROD SPECIAL	24	
*	5	93450-18169	CIRCLIP	24	
*	6	3P6-12129-00	SEAL, VALVE STEM OIL 2	24	INT
*	7	4TE-12119-00	SEAL, VALVE STEM OIL	24	EXT
°	8	2CR-13414-70	GASKET, STRAINER	3	OIL PAN
°	9	2CR-15451-70	GSKT., CRANKCASE COVER 1	3	CLUTCH
°	10	2CR-15461-70	GSKT., CRANKCASE COVER 2	3	CLUTCH
°	11	2CR-15456-70	GSKT., 1	3	PICK UP
*	12	2CR-15462-00	GSKT., CRANKCASE COVER 3	3	BREATHER
*	13	93102-40330	SEAL, OIL	3	DRIVE AXLE
*	14	90149-06082	SCREW	9	MAIN AXLE
*	15	90119-09010	BOLT, HEX. W/WASHER	30	CRANK JOURNAL BOLT
*	16	93210-07540	O-RING	24	BALANCER BOLT

These sets of parts necessary for engine disassembly and maintenance are provided in three (3) sets.

8. Spark Plug Set (14B-R465B-70)

Parts List

No.	PART No.	PART NAME	Q'TY	REMARKS
1	14B-1119C-70	PLUG, SPARK	4	NGK R0465B-10

The spark creating portion of this spark plug is of a semi-surface discharge type of shape.

TIP

Since these spark plugs have a copper gasket, caution is needed during installation on the following points.

1. The tightening torque is 12 – 15 N•m (1.2 – 1.5 kgf•m).
2. When not checking the torque, tighten by rotating through 30° after manual tightening in the case of new plugs. When reusing plugs, tighten by rotating through 15° .

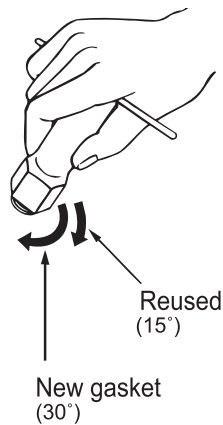

9. Piston Set (2CR-116A0-71)

Parts List

	No.	PART No.	PART NAME	Q'TY	REMARKS
*	1	2CR-11631-10	PISTON	4	
*	2	2CR-11603-10	PISTON RING SET	4	
*	3	2CR-11633-00	PIN, PISTON	4	
*	4	93450-18169	CIRCLIP	8	

This set consists of a combination of four genuine pistons so that the weight difference of each item does not exceed 0.5 g.

10. Connecting Rod Set (2CR-1165B-70)

Parts List

	No.	PART No.	PART NAME	Q'TY	REMARKS
*	1	2CR-11650-00	CONN. ROD ASSY. 1	4	

This set consists of four genuine connecting rod assemblies and the weight difference of each item does not exceed 2 g and combine them so that the small end weights are uniform.(by Yamaha's measuring method)

11. Crankshaft (2CR-11400-71)

Parts List

	No.	PART No.	PART NAME	Q'TY	REMARKS
*	1	2CR-11400-10	CRANK ASSY.	1	

This item is a genuine crankshaft with good balance.

About compatibility between the piston set, connecting rod set and crankshaft (by model year)

MODEL	Piston Set	Connecting Rod Set	Crankshaft
2015	2CR-116A0-70	2CR-1165B-70	2CR-11400-70
2016	2CR-116A0-71		2CR-11400-71
2017			

Piston set:

As the component parts (piston and piston ring) of the 2016/2017 models are different from that of the 2015 model, the 2015 and 2016/2017 models are not compatible each other.

Be sure to use a combination of a piston and a piston ring of same model year.

Since the piston set of the kit consists of pistons, piston rings and piston pins, the set enables installing those items on any model-year engine at once.

Connecting rod:

No change.

Crankshaft:

As a thrust bearing is added to the #4 cylinder for the 2016/2017 model engine, the 2015 and 2016/2017 models are not compatible each other.

The 2015 model crankshaft is currently not available in the kit.

Please purchase a Yamaha genuine part when a 2015 model crankshaft is needed.

12. High-lift Camshafts, Cam Sprocket

High-lift Camshafts

Parts List

No.	PART No.	PART NAME	Q'TY	REMARKS
1	2CR-12170-70	SHAFT, CAM 1	1	INT
2	2CR-12180-70	SHAFT, CAM 2	1	EXT

Cam Sprocket

Parts List

No.	PART No.	PART NAME	Q'TY	REMARKS
3	2CR-12176-70	SPROCKET, CAM	1	INT/EXT-shared use

This camshaft has a cam profile etc. changed from the STD one.

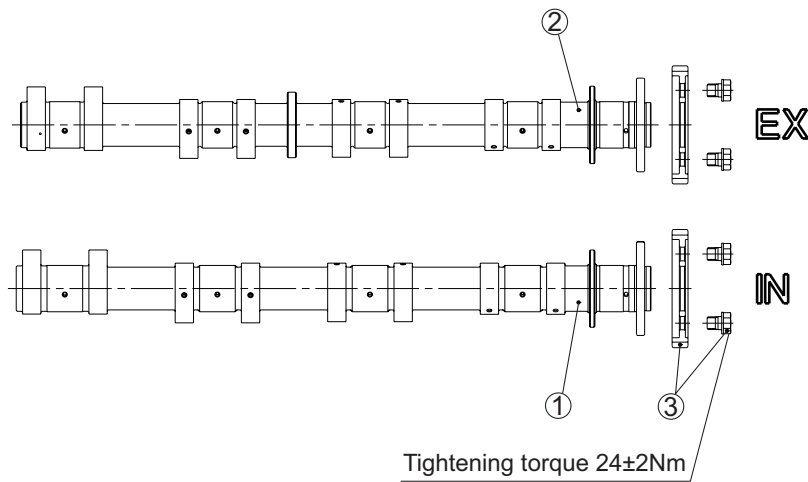

Possible to adjust the valve timing using the long holes on the cam sprocket.

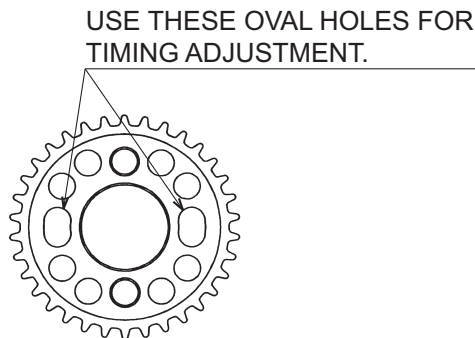

The set of the camshaft, valve spring, ECU and air funnel must be used in the following combination.

NOTICE

Using in other combinations may possibly damage the engine.

Be sure to use in the combination as stated below.

MODEL	CAMSHAFT (IN)	CAMSHAFT (EX)	VALVE SPRING	ECU	AIR FUNNEL SET
2015			2CR-A2110-70	2CR-8591A-70	MGC-191114-00
2016	2CR-12170-70	2CR-12180-70	2CR-A2110-71	2CR-8591A-71	2CR-1440B-70
2017			2CR-A2110-71	2CR-8591A-72	

Installation

1. Fit the scratch line on the camshaft to the compression top dead point 105 degree (K mark position) to combine the camshaft and cylinder head surface.
2. Adjust the valve timing (to the value stated on the normal specifications) using the long holes.

TIP

Install the cam sprocket as the scratch line and 2CR mark face the outside of the engine.

<How to position at #1 cylinder's compression top dead point 105°>

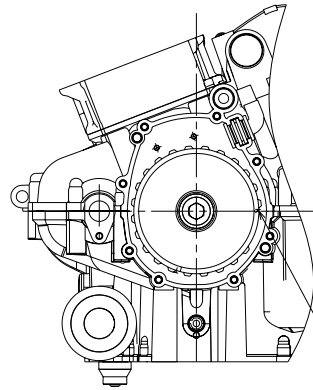

Fit the assembly (K) mark of the rotor assembly to the case surface line. (#1 cylinder compression top dead point 105 degree)

< Position to install the cam sprocket at #1 cylinder compression top dead point 105°>

Tighten using the long holes on the cam sprocket.

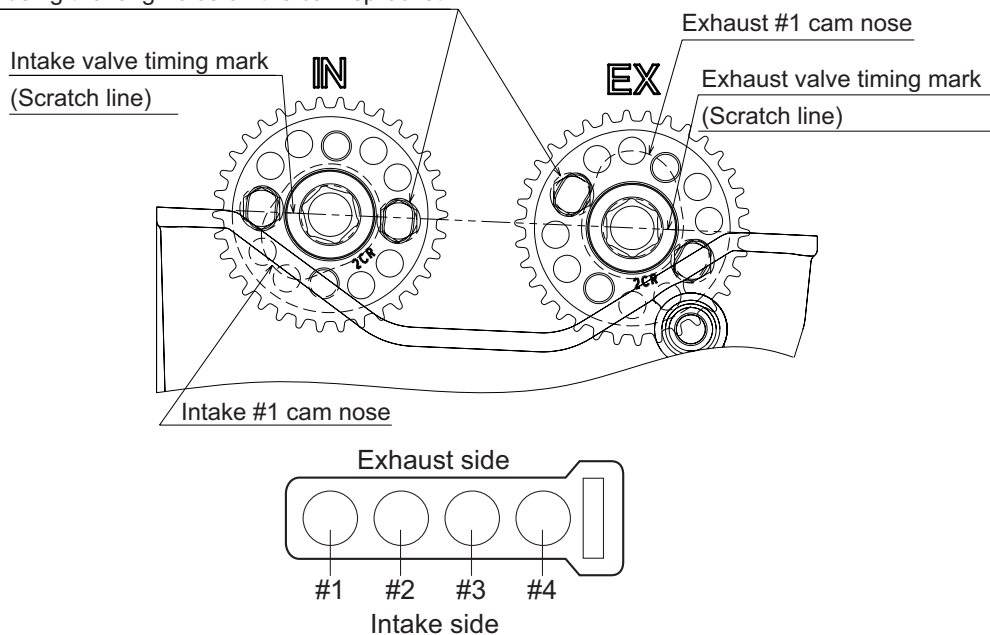

TIP

For valve timing adjustment, refer to the KIT TOOL MANUAL.

NOTICE

When fitting the camshaft, use the slotted holes of the cam sprockets and always set the timing to match. If otherwise, no intended performance can be expected and more over, the engine may be damaged.

13. Valve Spring Set (2CR-A2110-71)

Parts List

No.	PART No.	PART NAME	Q'TY	REMARKS
1	2CR-12130-70	SPRG' ASSY. 1	8	I.D.Color: Blue (INT)
2	2CR-12140-70	SPRG' ASSY. 2	8	I.D.Color: Red (EXT)
*	3	2CR-12117-00	8	RET.VALVE SPRING INT
*	4	2CR-12127-00	8	RET.VALVE SPRING 2 EXT

This valve spring is used when the camshaft is mounted from the kit.

This set consists of a valve spring, a valve spring seat and a retainer valve spring.

While the valve spring of the 2017 model employs double-spring structure, that of the kit parts employs single-spring structure.

When applying this set to the 2017 model, replace whole corresponding parts with this set.

When applying this set to the 2015/2016 model, you do not need to replace with the retainer valve spring of this set (installation is possible).

The set of the camshaft, valve spring, ECU and air funnel must be used in the following combination.

MODEL	CAMSHAFT (IN)	CAMSHAFT (EX)	VALVE SPRING	ECU	AIR FUNNEL SET
2015			2CR-A2110-70	2CR-8591A-70	MGC-191114-00
2016	2CR-12170-70	2CR-12180-70	2CR-A2110-71	2CR-8591A-71	2CR-1440B-70
2017			2CR-A2110-71	2CR-8591A-72	

NOTICE

Using in other combinations may possibly damage the engine.

Be sure to use in the combination as stated above.

14. Air Funnel Set (2CR-1440B-70)

Parts List

No.	PART No.	PART NAME	Q'TY	REMARKS
1	2CR-14479-70	SECONDARY FUNNEL	1	
2	2CR-14469-70	PRIMARY FUNNEL 1	1	
3	92014-06025	BUTTON HEAD BOLT	3	
4	2CR-1446C-70	PRIMARY FUNNEL 2	1	
5	92014-06025	BUTTON HEAD BOLT	3	

Installation

1. Assembling the primary funnel
Secure the primary funnel 1 and 2 to the throttle body with the supplied button head bolts. At this time, install the STD lever 1 and 2 and fix them.

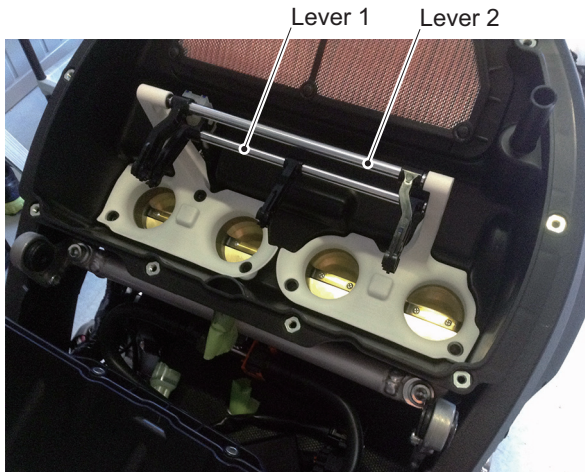

2. Assembling the secondary funnel
Install the secondary funnel to the lever 1 and 2. Then, fit the STD bushes to the lever assembling positions. (5 locations)

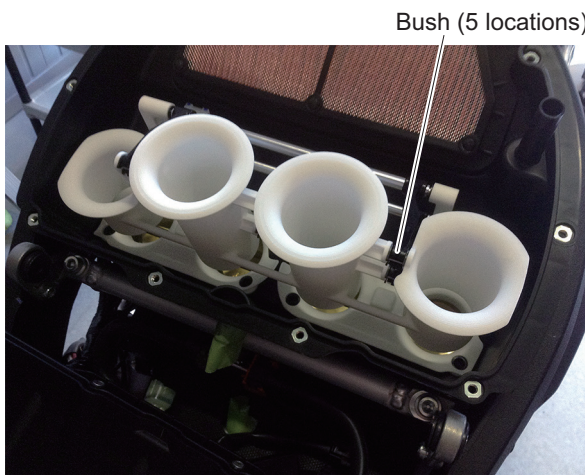

TIP

The STD seal rubber is not used at the bottom surface (face to the primary funnel) of the secondary funnel.

Ycci System Control

You can use the Ycci system as the kit funnel. You can control the operation timing by using the YMS software packed together with the kit ECU.

You can also control the STD funnel by using the YMS software.

The set of the camshaft, valve spring, ECU and air funnel must be used in the following combination.

NOTICE

Using in other combinations may possibly damage the engine.

Be sure to use in the combination as stated below.

MODEL	CAMSHAFT (IN)	CAMSHAFT (EX)	VALVE SPRING	ECU	AIR FUNNEL SET
2015			2CR-A2110-70	2CR-8591A-70	MGC-191114-00
2016	2CR-12170-70	2CR-12180-70	2CR-A2110-71	2CR-8591A-71	2CR-1440B-70
2017			2CR-A2110-71	2CR-8591A-72	

15. AIS-plug Set (2CR-A4890-70)

This plug set is used when the AIS (Air Induction System), an exhaust gas purifying system, is removed.

Parts List

No.	PART No.	PART NAME	Q'TY	REMARKS
1	5SL-1482L-70	PLATE, 2	2	
2	2CR-11159-70	PLUG, BLIND	4	
3	90336-10020	PLUG, TAPER	1	

Installation

1. Remove the hose attached to the cylinder head cover and the air cut-off valve accompanying the hose.
2. Remove the cap fitted to the hose, remove the reed valve and plate from inside.
3. Install the ① PLATE,2 (5SL-1482L-70) in replacement of the cap. Be sure to apply liquid gasket.
4. Remove the cylinder head cover and the four collars fitted to the head cover, and install the ② PLUG, BLIND (2CR-A4890-70).
5. After removing the hose connected to the air filter casing from the air-cut valve assembly, insert the ③ PLUG, TAPER (90336-10020) onto the side of the air filter casing to close the opening.

STD

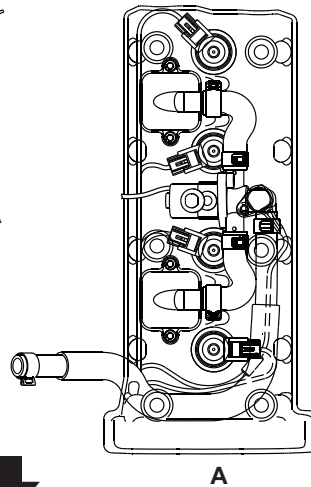
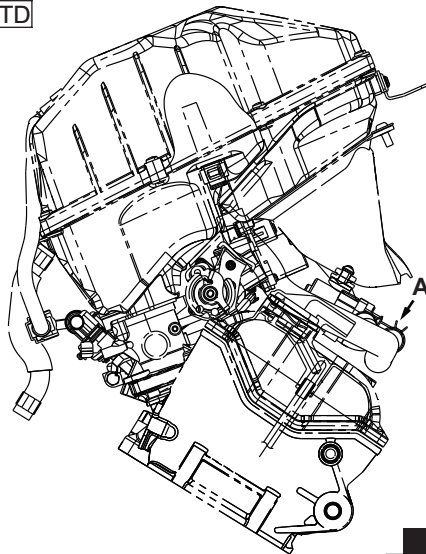

KIT

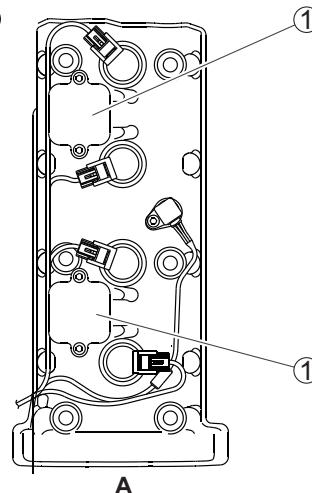
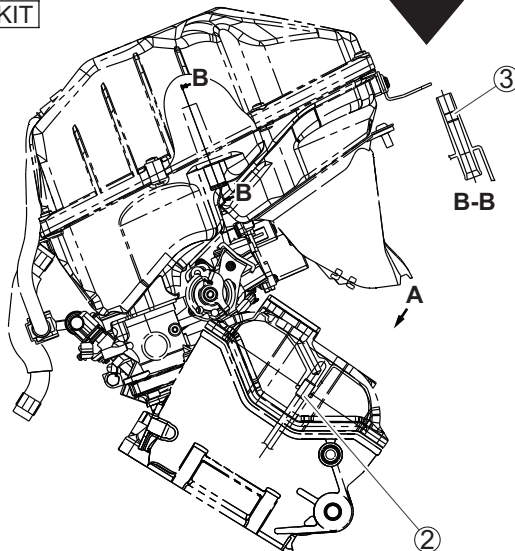

16. Transmission Gear

Parts List

	No.	PART No.	PART NAME	Q'TY	REMARKS
	1	2CR-17401-70	MAIN AXLE ASSY.	1	
	2	2CR-17121-70	GEAR, 2ND PINION	1	
	3	2CR-17131-70	GEAR, 3RD PINION	1	
	4	2CR-17151-70	GEAR, 5TH PINION	1	
	5	2CR-17161-70	GEAR, 6TH PINION	1	
*	6	2CR-17402-00	DRIVE, AXLE ASSY.	1	
	7	2CR-17211-70	GEAR, 1ST WHEEL	1	
	8	2CR-17221-70	GEAR, 2ND WHEEL	1	
	9	2CR-17231-70	GEAR, 3RD WHEEL	1	
	10	2CR-17241-70	GEAR, 4TH WHEEL	1	
	11	2CR-17251-70	GEAR, 5TH WHEEL	1	
	12	2CR-17261-70	GEAR, 6TH WHEEL	1	

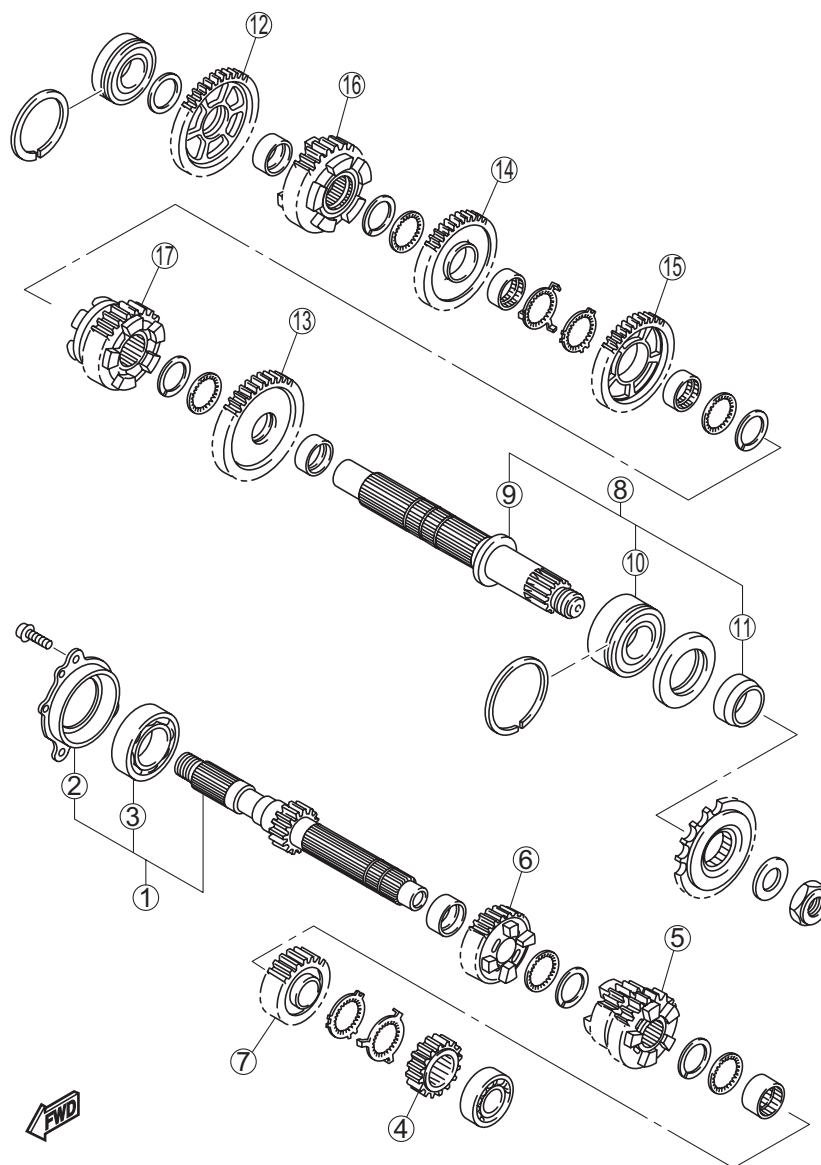

NOTICE

This set contains modified gear ratios and docks compared with the STD gearbox. Kit gears cannot use combine standard gear.

Gear ratio

	STD	KIT
1st	39/15 (2.600)	39/16 (2.438)
2nd	37/17 (2.176)	35/17 (2.059)
3rd	35/19 (1.842)	34/19 (1.789)
4th	30/19 (1.579)	33/21 (1.571)
5th	29/21 (1.381)	32/22 (1.455)
6th	30/24 (1.250)	30/22 (1.364)

YZF-R1 Speed List

Engine speed (rpm) 13900

Primary reduction ratio 1.63

Tire diameter (mm) 642

GEAR	PLAN	The number of teeth		Ratio	16	16	16	15	16	15	16	15	16	14	15	16	14	15	16	14	15	16
		P	W		38	39	40	38	41	39	42	40	43	38	41	44	39	42	45	40	43	46
1st	STD	15	39	2.60	166.6	162.3	158.3	156.2	154.4	152.2	150.7	148.4	147.2	145.8	144.8	143.9	142.0	141.3	140.7	138.5	138.0	137.6
	KIT	16	39	2.44	177.7	173.2	168.8	166.6	164.7	162.3	160.8	158.3	157.1	155.5	154.4	153.5	151.5	150.7	150.1	147.7	147.2	146.8
2nd	STD	17	37	2.18	199.0	193.9	189.1	186.6	184.5	181.8	180.1	177.3	175.9	174.2	172.9	171.9	169.7	168.8	168.1	165.4	164.9	164.4
	KIT	17	35	2.06	210.4	205.0	199.9	197.3	195.0	192.2	190.4	187.4	185.9	184.1	182.8	181.7	179.4	178.5	177.7	174.9	174.3	173.8
3rd	STD	19	35	1.84	235.2	229.1	223.4	220.5	218.0	214.8	212.8	209.4	207.8	205.8	204.3	203.1	200.5	199.5	198.6	195.5	194.8	194.3
	KIT	19	34	1.79	242.1	235.9	230.0	226.9	224.4	221.1	219.0	215.6	213.9	211.8	210.3	209.1	206.4	205.3	204.4	201.2	200.6	200.0
4th	STD	19	30	1.58	274.4	267.3	260.6	257.2	254.3	250.6	248.2	244.3	242.5	240.1	238.4	236.9	233.9	232.7	231.7	228.1	227.3	226.6
	KIT	21	33	1.57	275.7	268.6	261.9	258.4	255.5	251.8	249.4	245.5	243.6	241.2	239.5	238.1	235.0	233.8	232.8	229.1	228.4	227.7
5th	STD	21	29	1.38	313.7	305.6	298.0	294.1	290.7	286.5	283.8	279.4	277.2	274.5	272.6	270.9	267.4	266.1	264.9	260.8	259.9	259.1
	KIT	22	32	1.45	297.8	290.2	282.9	279.2	276.0	272.0	269.5	265.2	263.2	260.6	258.8	257.2	253.9	252.6	251.5	247.6	246.7	246.0
6th	STD	24	30	1.25	346.6	337.7	329.2	324.9	321.2	316.6	313.5	308.6	306.3	303.2	301.1	299.3	295.5	293.9	292.6	288.1	287.1	286.3
	KIT	22	30	1.36	317.7	309.5	301.8	297.8	294.4	290.2	287.4	282.9	280.7	278.0	276.0	274.4	270.8	269.5	268.3	264.1	263.2	262.4

GEAR	PLAN	The number of teeth		Ratio	14	15	16	16	15	14	16	15	14	15	14	15	14	15	14	14	14	14
		P	W		41	44	47	48	45	42	49	46	43	47	44	48	45	49	46	47	48	49
1st	STD	15	39	2.60	135.1	134.9	134.7	131.9	131.9	131.9	129.2	129.0	128.8	126.3	125.9	123.7	123.1	121.1	120.4	117.9	115.4	113.1
	KIT	16	39	2.44	144.1	143.9	143.7	140.7	140.7	140.7	137.8	137.6	137.4	134.7	134.3	131.9	131.3	129.2	128.5	125.7	123.1	120.6
2nd	STD	17	37	2.18	161.4	161.1	160.9	157.6	157.6	157.6	154.4	154.1	153.9	150.9	150.4	147.7	147.1	144.7	143.9	140.8	137.9	135.1
	KIT	17	35	2.06	170.6	170.4	170.1	166.6	166.6	166.6	163.2	162.9	162.7	159.5	159.0	156.2	155.5	153.0	152.1	148.9	145.7	142.8
3rd	STD	19	35	1.84	190.7	190.4	190.1	186.2	186.2	186.2	182.4	182.1	181.8	178.2	177.7	174.5	173.8	171.0	170.0	166.4	162.9	159.6
	KIT	19	34	1.79	196.3	196.0	195.7	191.6	191.6	191.6	187.7	187.5	187.2	183.5	182.9	179.7	178.9	176.0	175.0	171.3	167.7	164.3
4th	STD	19	30	1.58	222.5	222.1	221.8	217.2	217.2	217.2	212.8	212.5	212.1	208.0	207.3	203.6	202.7	199.5	198.3	194.1	190.0	186.2
	KIT	21	33	1.57	223.6	223.2	222.9	218.2	218.2	218.2	213.8	213.5	213.2	208.9	208.3	204.6	203.7	200.4	199.3	195.0	191.0	187.1
5th	STD	21	29	1.38	254.4	254.0	253.6	248.3	248.3	248.3	243.3	242.9	242.6	237.8	237.0	232.8	231.8	228.1	226.7	221.9	217.3	212.9
	KIT	22	32	1.45	241.5	241.1	240.8	235.8	235.8	235.8	231.0	230.6	230.3	225.7	225.1	221.0	220.1	216.5	215.3	210.7	206.3	202.1
6th	STD	24	30	1.25	281.0	280.6	280.2	274.4	274.4	274.4	268.8	268.4	268.0	262.7	261.9	257.2	256.1	252.0	250.5	245.2	240.1	235.2
	KIT	22	30	1.36	257.6	257.2	256.8	251.5	251.5	251.5	246.4	246.0	245.6	240.8	240.1	235.8	234.7	231.0	229.6	224.7	220.1	215.6

17. Mission Maintenance Set (2CR-A7000-70)

Parts List

	No.	PART No.	PART NAME	Q'TY	REMARKS
*	21	90387-28003	COLLAR	3	
*	22	90209-25011	WASHER	6	
*	23	93440-28184	CIRCLIP	3	
*	24	90387-25023	COLLAR	3	
*	25	90214-25004	WASHER, CLAW	3	
*	26	90214-25003	WASHER, CLAW	3	
*	27	90387-31003	COLLAR	3	
*	28	90209-28008	WASHER	9	
*	29	93440-31187	CIRCLIP	9	
*	30	90387-28004	COLLAR	6	
*	31	90214-29002	WASHER, CLAW	3	
*	32	90214-28002	WASHER, CLAW	3	
*	33	90387-25008	COLLAR	3	
*	34	93102-40330	SEAL, OIL	3	
*	35	93440-62032	CIRCLIP	3	
*	36	90201-257H0	WASHER, PLAIN	3	
*	37	93306-27214	BRG.	3	
	38	5VY-17166-00	BRG., 2	3	

This kit contains three (3) sets of parts necessary for transmission disassembly and maintenance.

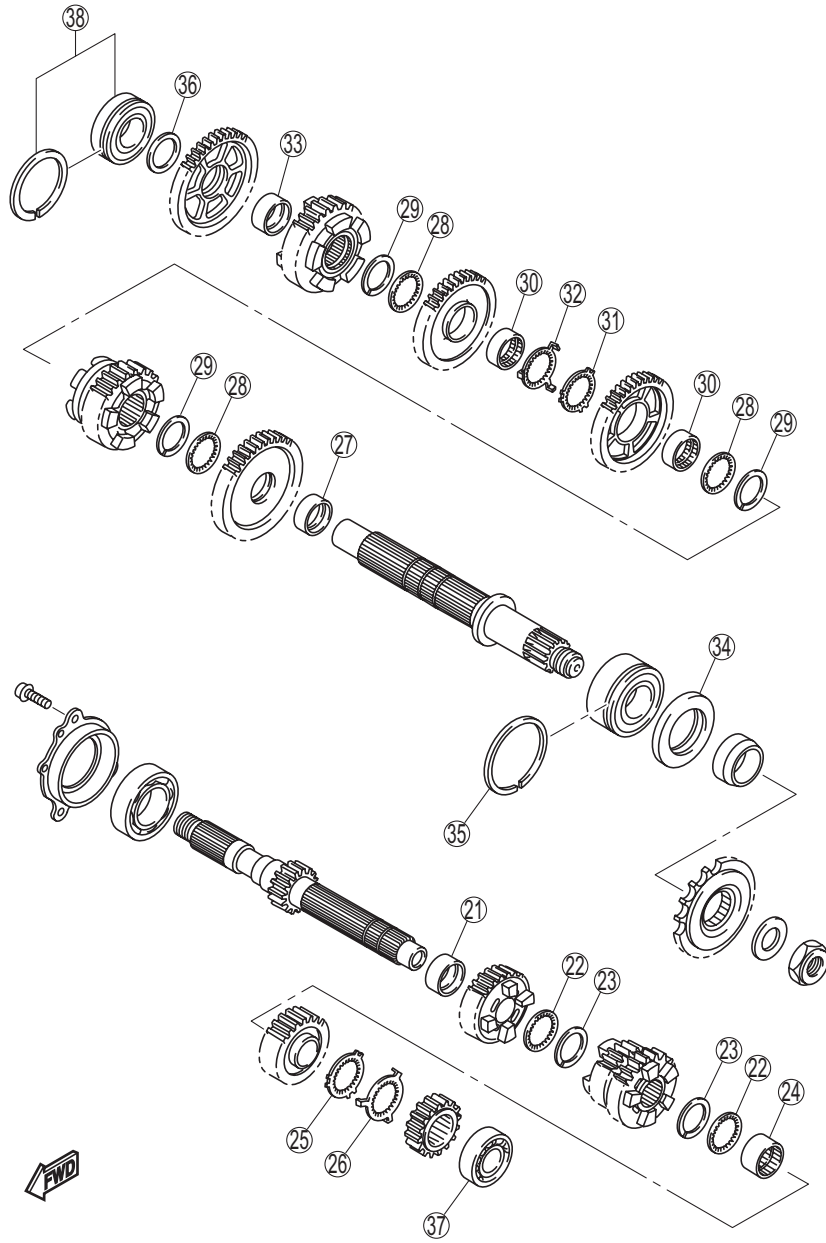

Transmission Assembly

The seal side should face outward (one side seal bearing) and press in the bearing cup all the way into the case until it touches bottom.

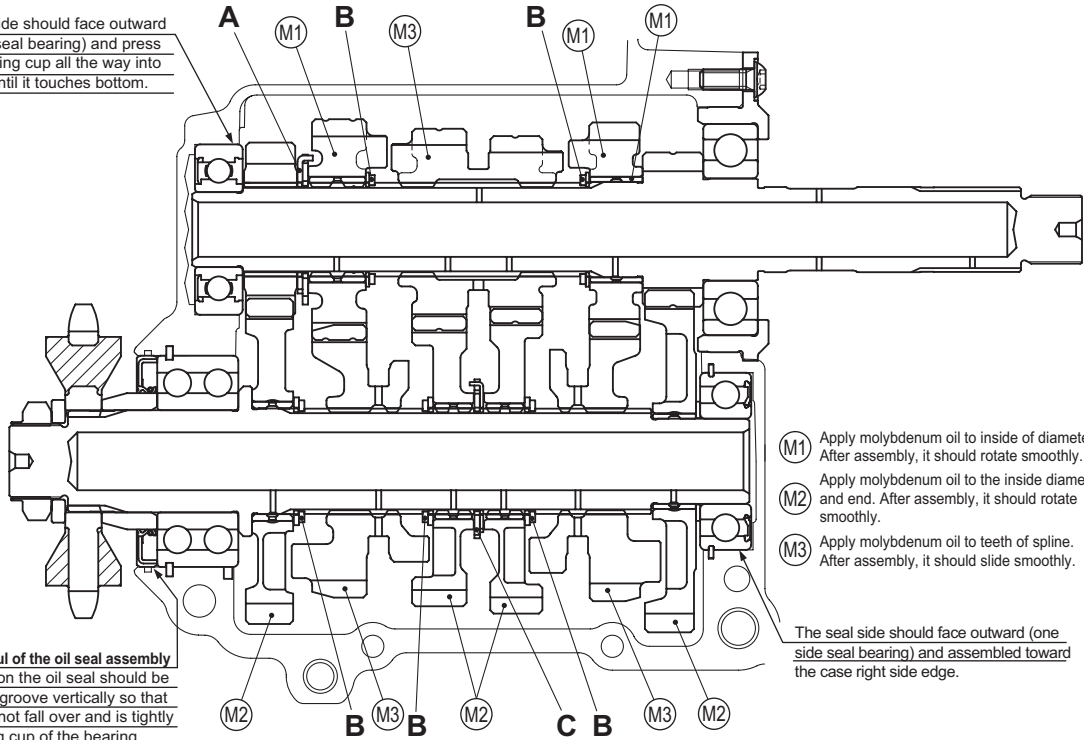

Points to be careful of the oil seal assembly
 The convex part on the oil seal should be put into the case groove vertically so that the oil seal does not fall over and is tightly fit into the bearing cup of the bearing.
 (Apply grease to the lip.)

- (M1) Apply molybdenum oil to inside of diameter. After assembly, it should rotate smoothly.
- (M2) Apply molybdenum oil to the inside diameter and end. After assembly, it should rotate smoothly.
- (M3) Apply molybdenum oil to teeth of spline. After assembly, it should slide smoothly.

The seal side should face outward (one side seal bearing) and assembled toward the case right side edge.

TIP

- Always use a new circlip.
- Do not mistake the washer and circlip directions.
 (See drawing below.)

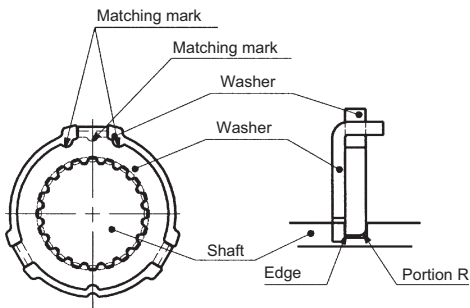

A Detail of installation of washer

Rotate washer so that its teeth meet axle-spline teeth on the axle, and then lock with washer's claw. Assemble washer with putting together their matching mark.

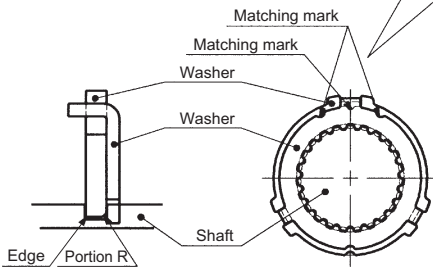

C Detail of installation of washer

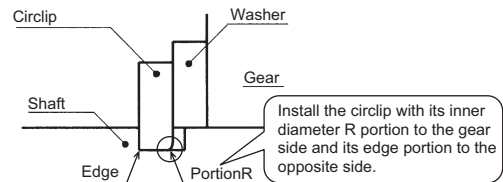

Install the circlip with its inner diameter R portion to the gear side and its edge portion to the opposite side.

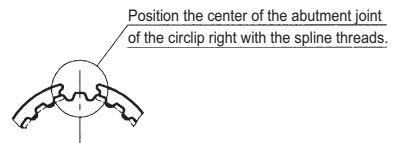

Position the center of the abutment joint of the circlip right with the spline threads.

B Detail of installation of circlip

18. Drive Sprockets

Parts List

No.	PART No.	PART NAME	Q'TY	REMARKS
1	2CR-17460-74	SPROCKET, DRIVE	1	14T, 520SIZE
2	2CR-17460-75	SPROCKET, DRIVE	1	15T, 520SIZE
3	2CR-17460-76	SPROCKET, DRIVE	1	16T, 520SIZE

This sprocket is weight-saved by changing the chain size to 520 in relation to the STD one.

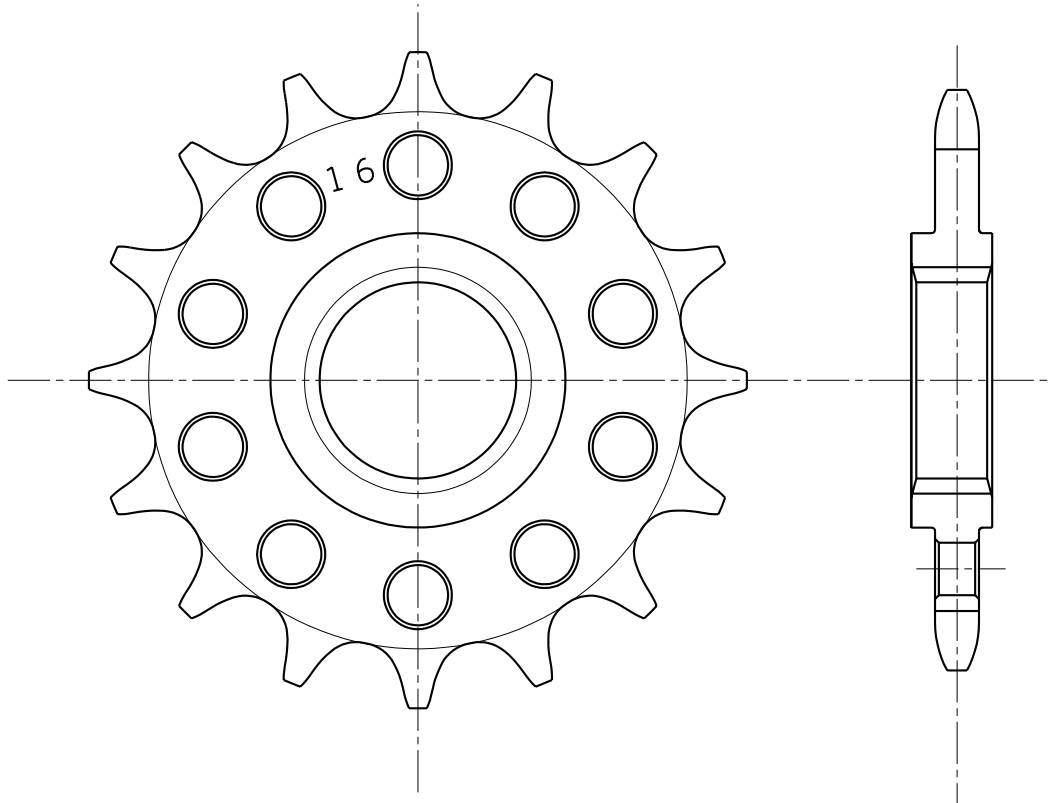

19. Sprocket Nut Set (2CR-A7463-70)

Parts List

	No.	PART No.	PART NAME	Q'TY	REMARKS
*	1	90179-22018	NUT	3	
*	2	90208-22002	WASHER, CONICAL SPRG.	3	

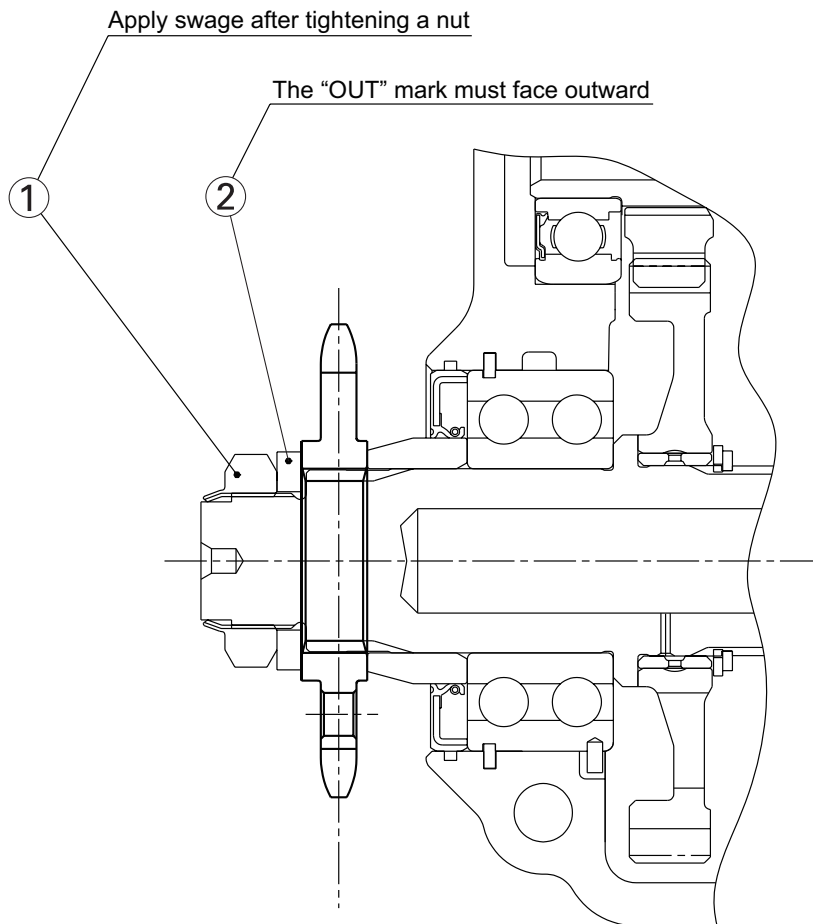

20. Strainer Cover Set (2CR-13400-70)

Parts List

No.	PART No.	PART NAME	Q'TY	REMARKS
1	2CR-13410-70	STRAINER HSG. ASSY.	1	
2	2CR-13576-70	SPACER	1	
*	93210-22M93	O-RING	2	2 attachment, Grease outer surface
*	92017-06014	BOLT,BUTTON HEAD	2	2 attachment
*	90110-06172	BOLT,HEX. SOCKET	2	1 attachment
6	2CR-13418-70	PIPE,OIL 2	1	
7	2CR-13416-70	PIPE,OIL 1	1	
*	93210-14003	O-RING	3	6, 7 attachment, Grease outer surface
*	90110-06393	BOLT,HEX. SOCKET	1	6 attachment
*	90110-06182	BOLT,HEX. SOCKET	1	7 attachment
11	2CR-13161-70	PIPE,DELIVERY 1	1	
*	90480-13010	GROMMET	1	11 attachment
*	5VY-13117-10	COLLAR,DISTANCE	1	11 attachment
*	90110-06172	BOLT,HEX. SOCKET	1	11 attachment
15	2CR-1310A-70	PAN,OIL	1	The number of the oil window changed: 2 ('16 kit) → 1 ('17 kit)
*	92012-06025	BOLT,BUTTON HEAD	12	15 attachment
*	90340-14019	PLUG,STRAIGHT SCREW	1	
*	90430-14005	GASKET	1	
19	2CR-13414-70	GASKET,STRAINER	1	1 attachment
20	2CR-13317-70	BAFFLE,PLATE	1	
*	90119-06115	BOLT	4	20 attachment

The tightening torque of this set is same as that of STD.

Use the screw locking solvent and grease same as STD.

For details, refer to the STD service manual published by Yamaha Motor Co.,Ltd.

For details on installation of this set, see the next page.

Meaning of the symbol marks in the figures



: Apply LOCTITE 620



: Tighten based on the specified tightening torque

Installation

1. Put 8 O-RING at 7 PIPE,OIL 1, and connect with 6 PIPE,OIL 2, then attach 6 PIPE,OIL 2 to the engine by using 8 O-RING and 9 BOLT,HEX. SOCKET,

and attach 7 PIPE,OIL 1 to the engine by using 10 BOLT,HEX. SOCKET.
Attach 2 SPACER to the engine by using 3 O-RING and 4 BOLT,BUTTON HEAD.

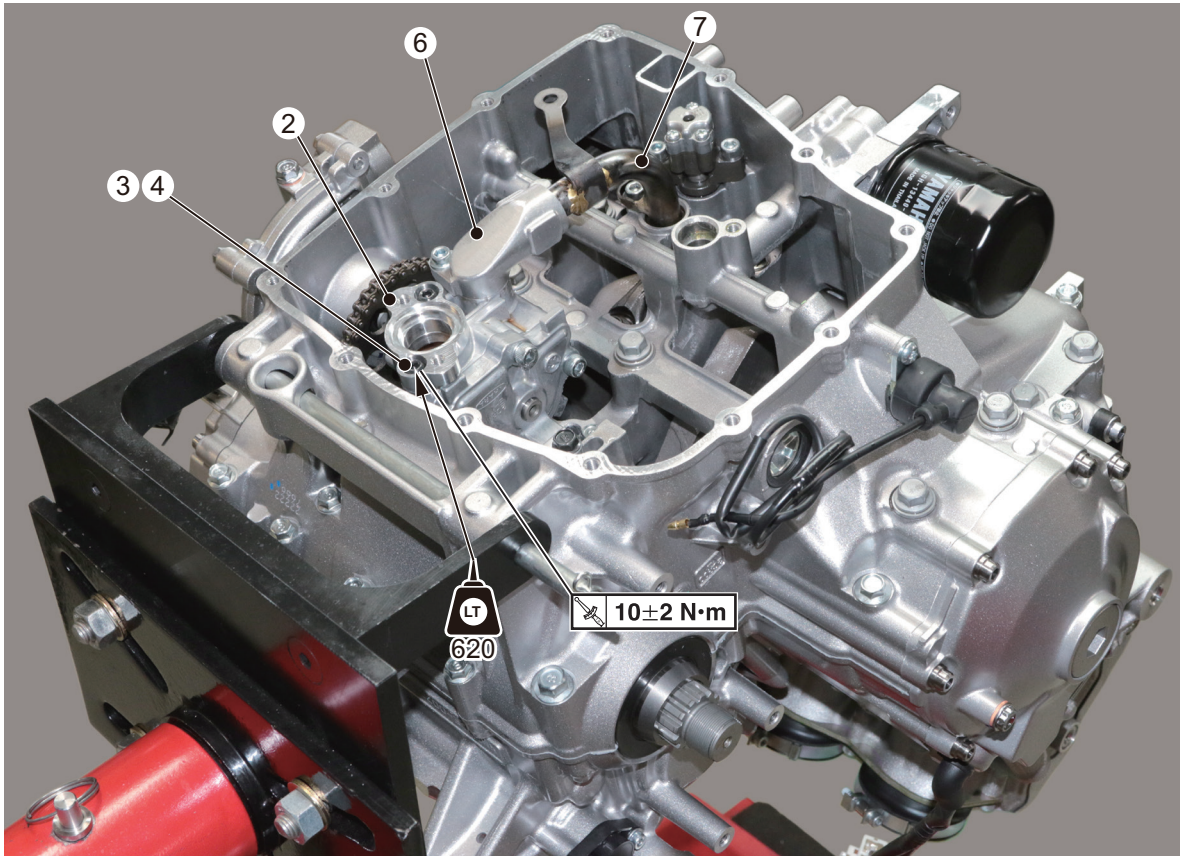

2. Attach 11 PIPE,DELIVERY 1 to the engine by using 12 GROMMET, 13 COLLAR, DISTANCE and 14 BOLT,HEX. SOCKET.

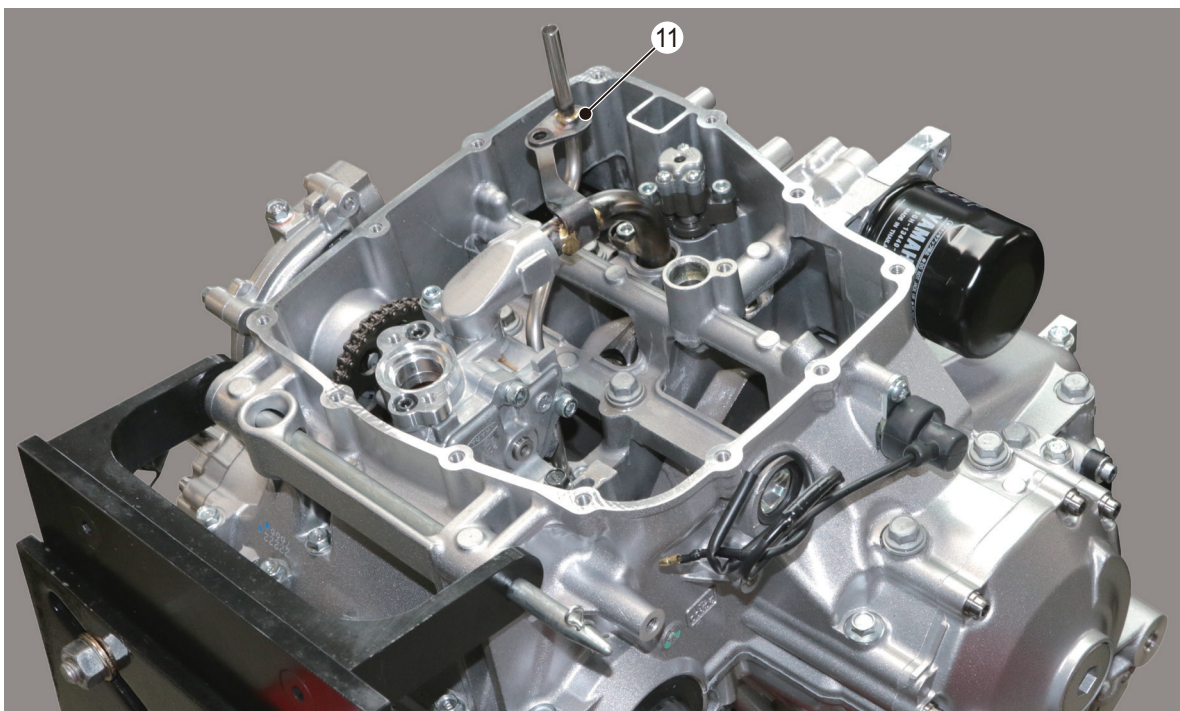

3. Attach 1 STRAINER HSG. ASSY. to the engine by using 5 BOLT,HEX. SOCKET and 19 GASKET,STRAINER.

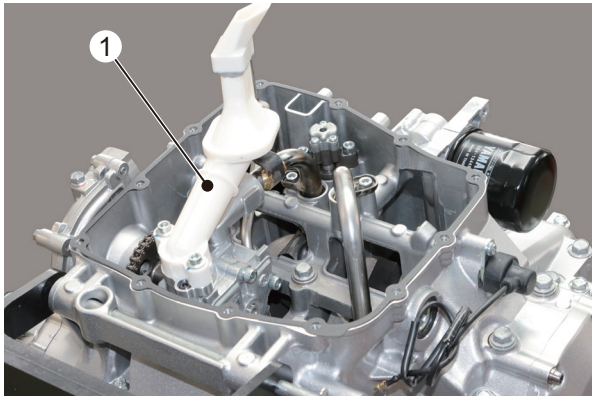

6. Attach 17 PLUG,STRAIGHT SCREW and 18 GASKET to 15 PAN,OIL.

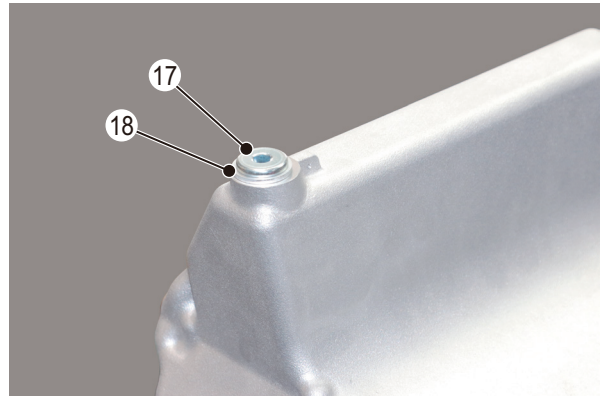

4. Attach 20 BAFFLE,PLATE to 15 PAN,OIL by using 21 BOLT.

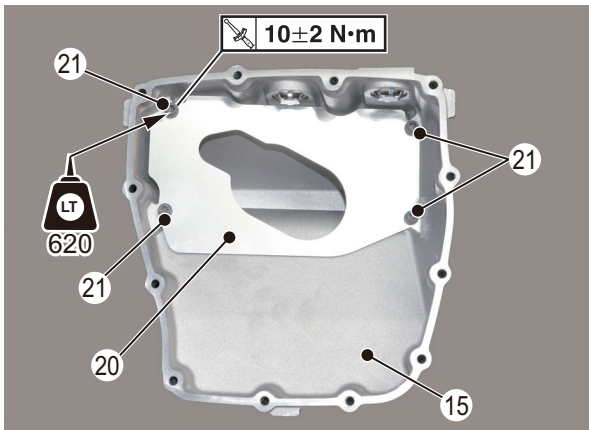

5. Attach 15 PAN,OIL to the engine by using 16 BOLT,BUTTON HEAD.

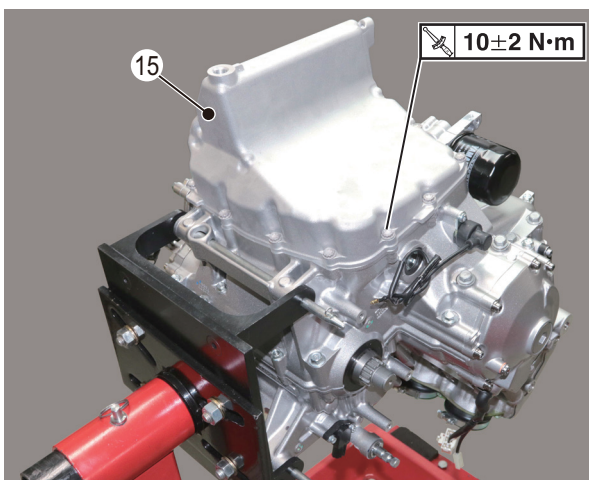

Recommended oil level

After engine warm-up (water temperature of 75 to 80 degrees), while using the racing (rear) stand, and check that the oil level is within a range of the upper limit of the oil pan window (right side of the vehicle) to the lower limit of the engine crank case oil window (left side of vehicle).

If it is out of range, adjust the oil level.

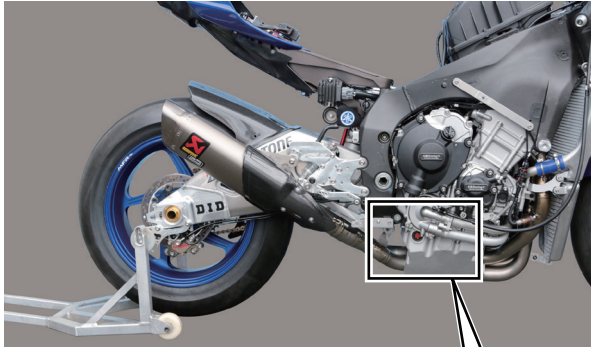

<Oil pan window (right side of vehicle)>

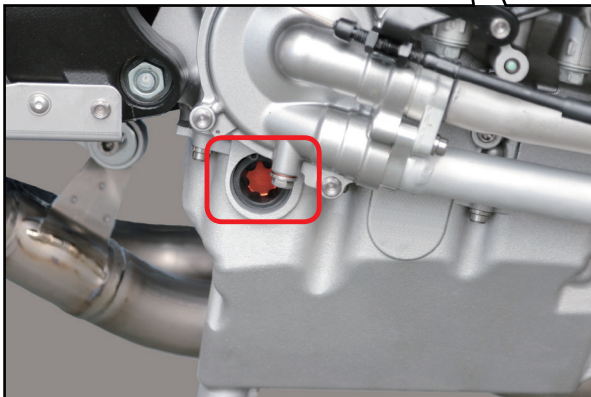

<Engine crank case oil window (left side of vehicle)>

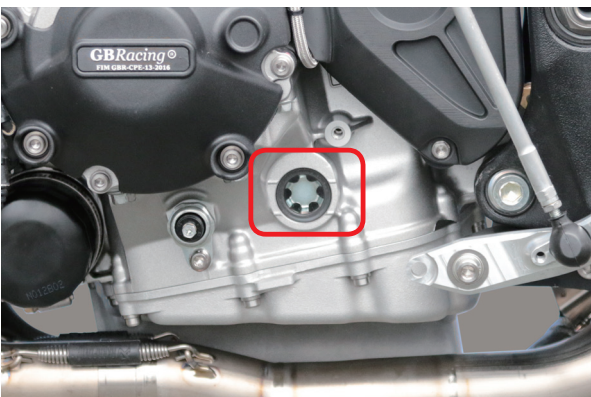

2-3 Installing Chassis Parts

21. Spring Rear Shock

Parts List

No.	PART No.	PART NAME	Q'TY	REMARKS
1	2CR-22222-A0	SPRG., REAR SHOCK	1	83 N/mm Identifying stamp: 159.5-56-83
2	2CR-22222-70	SPRG., REAR SHOCK	1	93 N/mm Identifying stamp: 159.5-56-93
3	2CR-22222-75	SPRG., REAR SHOCK	1	98 N/mm Identifying stamp: 159.5-56-98
4	2CR-22222-80	SPRG., REAR SHOCK	1	103 N/mm Identifying stamp: 159.5-56-103
5	2CR-22222-85	SPRG., REAR SHOCK	1	108 N/mm Identifying stamp: 159.5-56-108

- There is a stamp on the side of the springs for rate identification.
- Free length is 159.5 mm for the both STD spring and KIT spring.
- For spring replacement, see the 2CR STD. Service Manual.
- The spring rate of the standard rear suspension is 88 N/mm.

22. Spring Front Fork

Parts List

No.	PART No.	PART NAME	Q'TY	REMARKS
1	2CR-23141-A0	SPRG., FRONT FORK	1	8.5 N/mm Identifying slits 1-1
2	2CR-23141-70	SPRG., FRONT FORK	1	9.0 N/mm Identifying slits 1
3	2CR-23141-75	SPRG., FRONT FORK	1	9.5 N/mm Identifying slits 2
4	2CR-23141-80	SPRG., FRONT FORK	1	10.0 N/mm Identifying slits 3
5	2CR-23141-85	SPRG., FRONT FORK	1	10.5 N/mm Identifying slits 4

- There are slits at the ends of the spring for rate identification.
- For information about spring replacement, see 2CR STD. Service Manual.
- The spring rate of the STD is 9.0 N/mm.

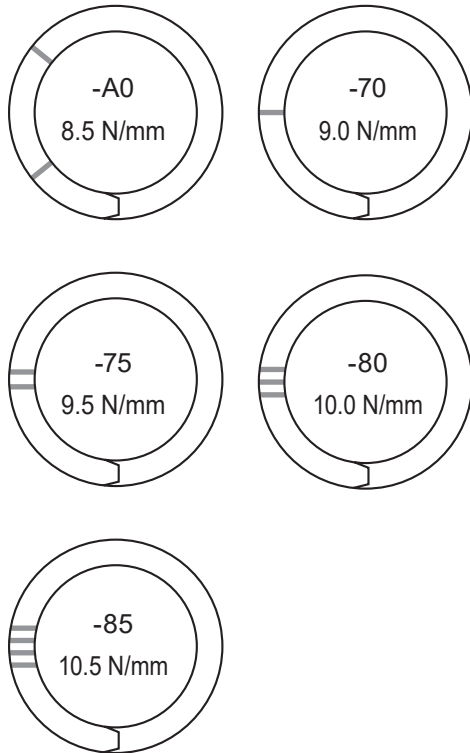

- There are slits at the ends of the spring for rate identification.
- Use the preload tube of the STD for installing the KIT spring.
- Free lengths are STD spring = 217.5mm and KIT spring = 215 mm.
 STD :Preload adjuster 0 mm = Actual preload 2.5 mm
 KIT :Preload adjuster 0 mm = Actual preload 0 mm

References

Front and rear load changes and front and rear suspension movement in different scenarios.

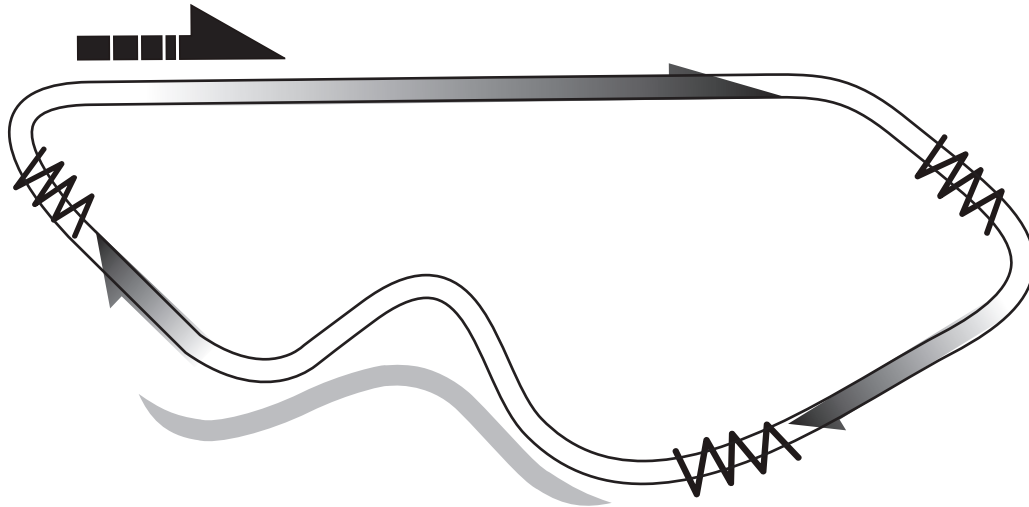

Accelerating

- Load change
The wider the throttle is opened, the more the load is concentrated on the rear.
- Front fork
Reaches nearly maximum extended stroke.
- Rear cushion
Up to 20 to 30mm stroke displacement, depending on conditions.

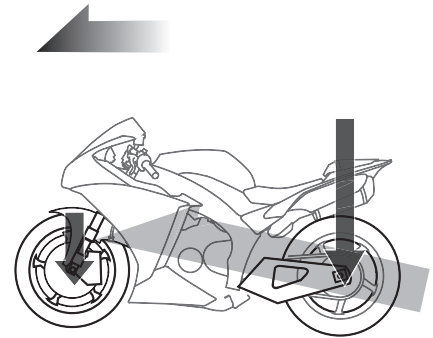

Braking

- Load change
The harder the brake is applied, the more the load is concentrated on the front.
- Front fork
Displaces until stroke has almost bottomed.
- Rear cushion
Reaches nearly maximum extended stroke.

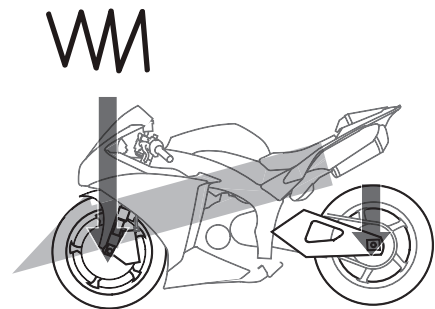

Cornering

- Load change
Increases the load on the front fork and rear cushion on both sides.
- Front fork
Up to 30 to 90mm stroke displacement depending on the size of the corner.
- Rear cushion
Up to 25 to 40mm stroke displacement, depending on conditions.

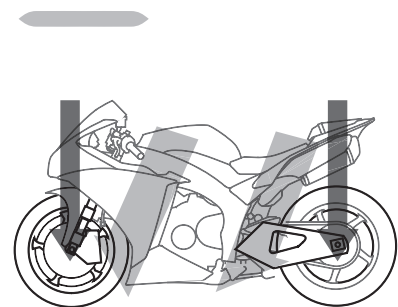

23. Seat Cushion (13S-24713-70)

Parts List

No.	PART No.	PART NAME	Q'TY	REMARKS
1	13S-24713-70	CUSHION SEAT	1	

Anti slip seat.

Cut to any size for use.



FWD

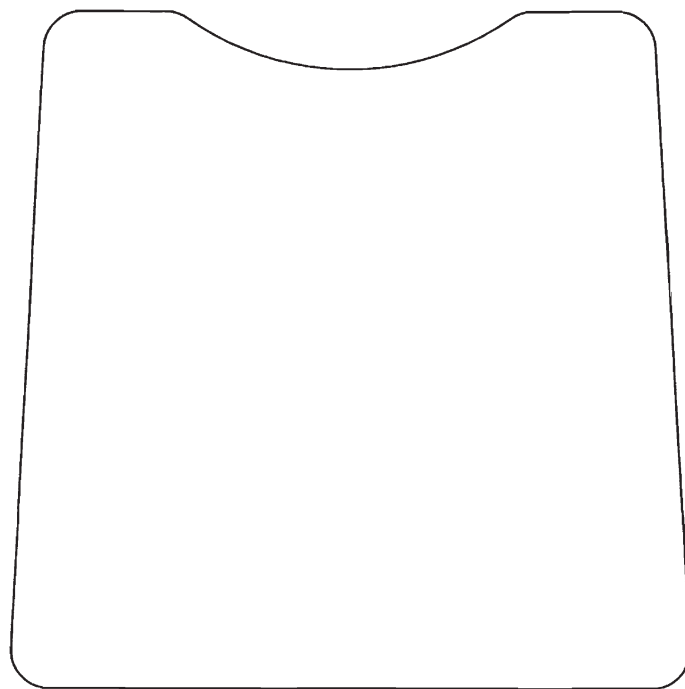

24. Front Spare Wheel ASS'Y (2CR-25100-70)

Parts List

No.	PART No.	PART NAME	Q'TY	REMARKS
1	2CR-25160-00	CAST WHEEL ASSY.	1	
*	2	93900-00030	1	VALVE, RIM
*	3	1SD-2517G-00	1	ROTOR, SENSOR
*	4	2CR-2514A-00	1	RING, WHEEL 1
*	5	90149-05037	5	SCREW
*	6	93210-47440	1	O-RING

*This kit does not include a tire.

This part is the STD wheel, bearing, spacer, air valve and center rotor combined.

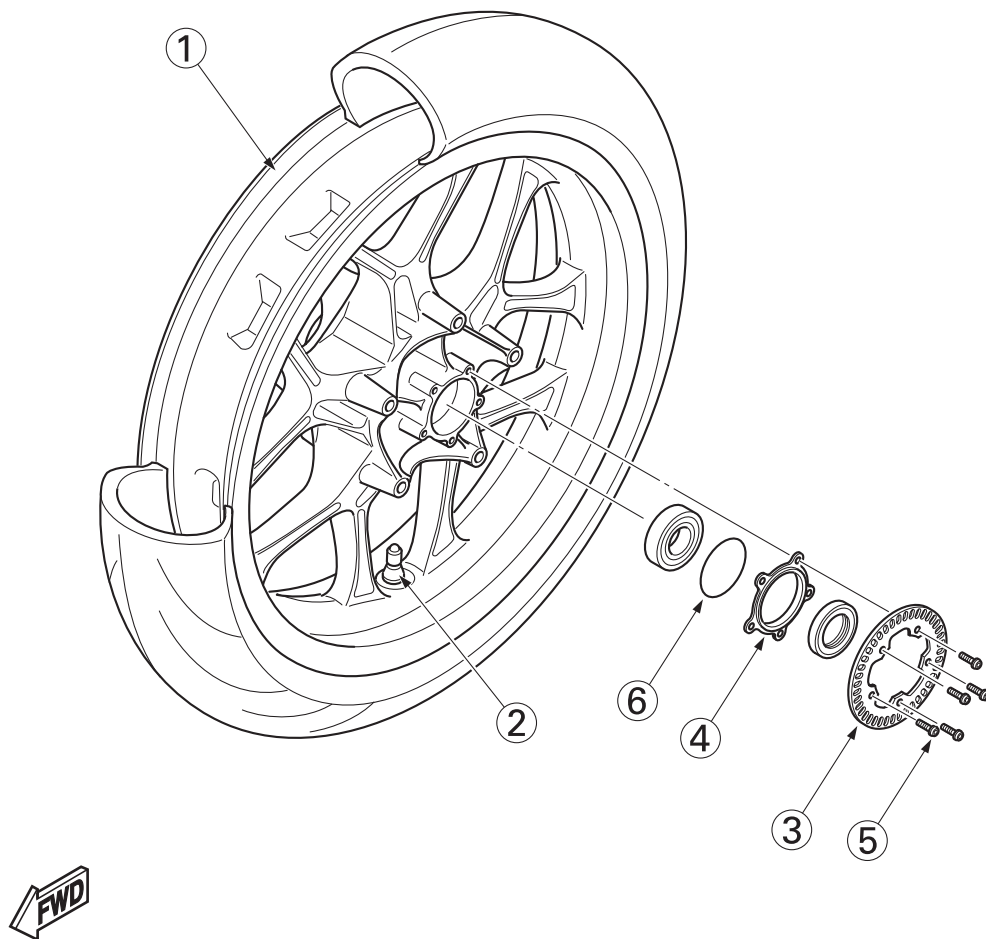

25. Rear Spare Wheel ASS'Y (2CR-25300-70)

Parts List

No.	PART No.	PART NAME	Q'TY	REMARKS
1	2CR-25370-00	CAST WHEEL ASSY.	1	
2	2CR-25840-00	DISK BRAKE ASSY.	1	
*	90111-08085	BOLT, HEX. SOCKET BUTTON	5	
*	93900-00030	VALVE, RIM	1	

*This kit does not include a tire.

This part is the STD wheel, bearing, spacer, air valve, rear disk brake and center rotor combined.

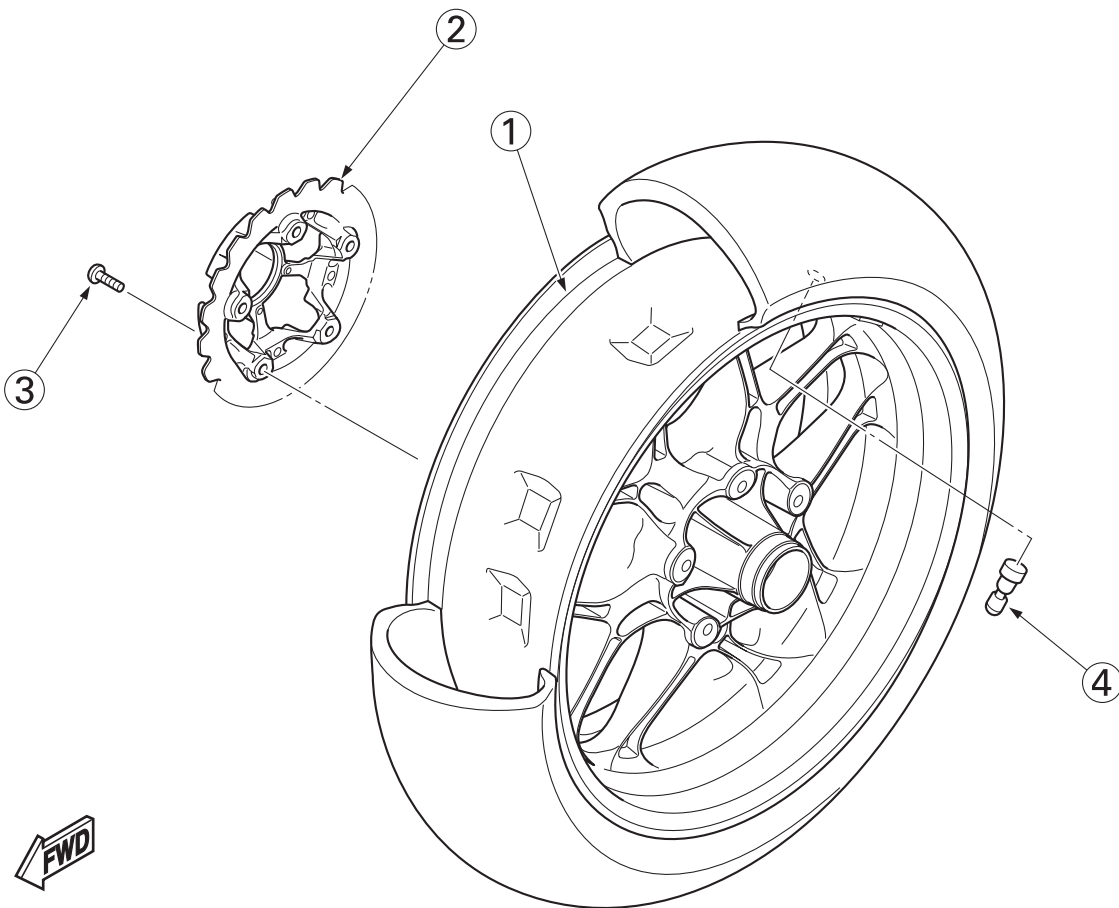

26. Tube Guide (2CR-26243-70)

Parts List

No.	PART No.	PART NAME	Q'TY	REMARKS
1	2CR-26243-70	TUBE, GUIDE	1	

About the Throttle Tube Guide Specifications

As shown below, the operating angle of the throttle grip when the throttle is fully opened is 57.5° as against STD 64.4° .

(Except this part, all other parts (such as a throttle wire) should be STD parts)

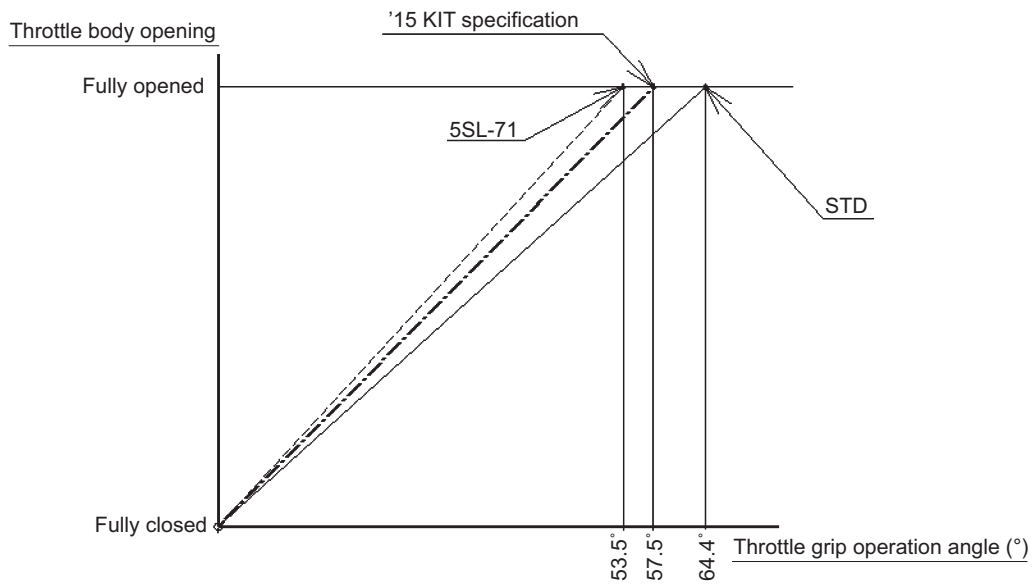

Installation

1. Replace the STD tube guide with the KIT tube guide.
2. As shown below, cut off the stopper inside the pull side cap grip.

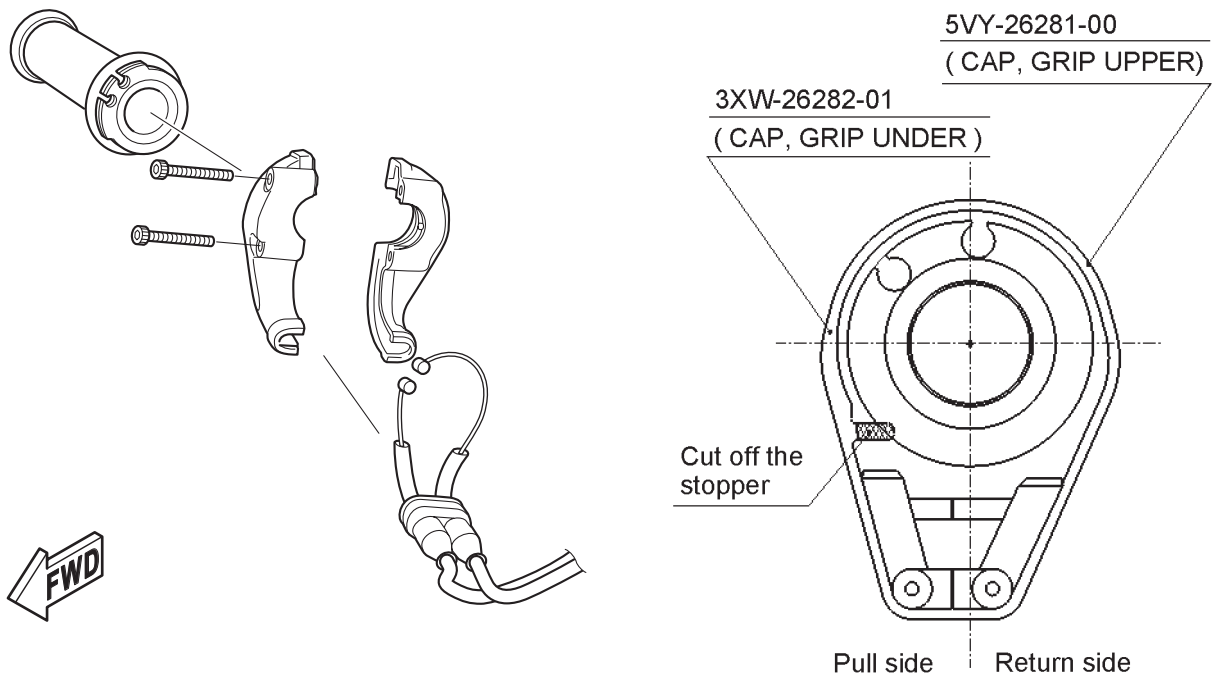

3 Tightening Torque List

Engine

To be tightened	Part No.	Part Name	Thread dia. x pitch	Tightening torque N•m (kgf•m)	Q'ty	Remarks
Plug for sand drain hole	90340-18004	PLUG, STRAIGHT SCREW	M18 × 1.5	25 ± 2 (2.5 ± 0.2)	2	APPLY LOCKING AGENT (LOCKTITE® TO BOTH SCREW THREAD AND TAPERED PORTION.
Install SPARK PLUG	94700-00424	PLUG, SPARK	M10S × 1.0	12 – 15 (1.2 – 1.5)	4	FOR DETAILS, SEE page 25.
Tighten HEAD	90119-09016	BOLT, HEXAGON WITH WASHER	M9 × 1.25	TURN OF NUT METHOD: AXIAL FORCE TARGET VALUE OF 40kN ± 2kN	10	FOR DETAILS, SEE page 65.
Tighten HEAD	90110-06315	BOLT, HEXAGON SOCKET HEAD	M6 × 1.0	12±2 (1.2±0.2)	2	
CAP x HEAD	90105-06027	BOLT, FLANGE	M6 x 1.0	[When using the bolt continuously] Apply oil to the bearing surface and thread part of the bolt, and tighten with tightening torque 8.0±1.0 N•m (0.8±0.1 kgf•m). [When replacing with a new bolt]	10	
CAP x HEAD	90105-06209	BOLT, FLANGE	M6 x 1.0	Tighten with tightening torque 10.0±2.0 N•m (1.0±0.2 kgf•m). It is not necessary to apply oil to the bearing surface and thread part of the bolt Use it in the delivery condition (corrosion- proof oil is applied).	10	
Tighten HEAD COVER	5VY-1119E-00	BOLT, COV- ER HEAD	M6 x 1.0	10±2 (1.0±0.2)	6	
Embedded in HEAD (Install EX.PIPE)	95612-08615	BOLT, STUD	M8 x 1.25	15±3 (1.5±0.3)	8	
AI CAP	90110-06175	BOLT, HEXAGON SOCKET HEAD	M6 x 1.0	10±2 (1.0±0.2)	4	APPLY TO SCREW ROCKING

Engine

To be tightened	Part No.	Part Name	Thread dia. x pitch	Tightening torque N•m (kgf•m)	Q'ty	Remarks
HEAD x JOINT, ASSY	90110-06168	BOLT, HEXAGON SOCKET HEAD	M6 x 1.0	10±2 (1.0±0.2)	6	APPLY TO SCREW ROCKING
ROCKER AXIS PLUG	90340-12013	PLUG, STRAIGHT SCREW	M12 x 1.0	10±2 (1.0±0.2)	3	APPLY TO SCREW ROCKING
ROCKER AXIS FIXING PIN	90109-05015	BOLT	M5 x 0.8	6±1 (6.0±0.1)	4	APPLY TO SCREW ROCKING
CON ROD	2CR-11654-00	BOLT, CON-ROD BIG END	M9 x 0.75	1.Remove oil from the bearing surface and female thread part of the con rod, and dry them for more than 5 min- utes. 2.Use an F-shaped torque wrench to tighten with initial tightening torque 25.0±2.0 N•m (2.5±0.2 kgf•m). 3.Apply additional tightening with angle 180±5°. 4.Check that the final tightening torque is 40.0 to 85.0 N•m (4.0 to 8.5 kgf•m). If not, replace the bolt with new one and re-tight it again.	8 each	* Do not leave EG oil or grease on the bearing sur- face or thread part of the bolt. * Do not apply/ remove oil to/ from the bolt. In case you have applied/remove to/from the bolt, replace it with new one. Use a new bolt only. Do not re- use the bolt.
ACM rotor	90109-10061	BOLT	M10 x 1.25	85±5 (8.5±0.5)	1	Remove oil from the taper surface. Apply oil to the bearing surface and thread part of the bolt, and the both sides of the washer.
SPROCKET, CRANK	2CR-12157-00	BOLT	M12 x 1.25	72±5 (7.2±0.5)	1	Apply oil to the bearing surface and thread part of the bolt.
CAM CHAIN, TENSIONER	90110-06178	BOLT, HEXAGON SOCKET HEAD	M6 x 1.0	10±2 (1.0±0.2)	2	APPLY TO SCREW ROCKING
Install PIPE 1, 4 (Water pump)	90110-06246	BOLT, HEXAGON SOCKET HEAD	M6 x 1.0	10±2 (1.0±0.2)	1	APPLY TO SCREW ROCKING. WATER PUMP SIDE

Engine

To be tightened	Part No.	Part Name	Thread dia. x pitch	Tightening torque N•m (kgf•m)	Q'ty	Remarks
Install THERMO- STAT ASSY.	90110-06163	BOLT, HEXAGON SOCKET HEAD	M6 x 1.0	10±2 (1.0±0.2)	2	The rear of the head cylinder
Install PIPE 1 (Body cylinder, case)	90105-06127	BOLT, FLANGE	M6 x 1.0	10±2 (1.0±0.2)	4	
PIPE 4 (Case)	91312-06014	BOLT, HEXAGON SOCKET HEAD	M6 x 1.0	10±2 (1.0±0.2)	1	
Install PUMP	91314-06035	BOLT, HEXAGON SOCKET HEAD	M6 x 1.0	10±2 (1.0±0.2)	2	
THERMOSTAT ASSY	90176-06017	CAP, NUT	M6 x 1.0	10±2 (1.0±0.2)	2	
Install OIL PUMP ASSY.	95817-06035	BOLT, FLANGE	M6 x 1.0	10±2 (1.0±0.2)	2	
	95817-06025	BOLT, FLANGE	M6 x 1.0	10±2 (1.0±0.2)	1	
Tighten DRAIN BOLT	90340-14019	PLUG, STRAIGHT SCREW	M14 x 1.5	23±2 (4.3±0.4)	1	
Install PIPE, OIL 1	90110-06182	BOLT, HEXAGON SOCKET HEAD	M6 x 1.0	10±2 (1.0±0.2)	2	APPLY TO SCREW ROCKING
Install HOUSING, STRAINER	90110-06173	BOLT, HEXAGON SOCKET HEAD	M6 x 1.0	10±2 (1.0±0.2)	3	APPLY TO SCREW ROCKING
Install RELIEF VALVE	90110-06169	BOLT, HEXAGON SOCKET HEAD	M6 x 1.0	10±2 (1.0±0.2)	2	APPLY TO SCREW ROCKING
Install PIPE HOLDER	90110-06182	BOLT, HEXAGON SOCKET HEAD	M6 x 1.0	10±2 (1.0±0.2)	2	APPLY TO SCREW ROCKING
Install oil delivery pipe 2	90110-06182	BOLT, HEXAGON SOCKET HEAD	M6 x 1.0	10±2 (1.0±0.2)	2	APPLY TO SCREW ROCKING
Install oil delivery pipe 5	90149-06158	SCREW	M6 x 1.0	10±2 (1.0±0.2)	1	APPLY TO SCREW ROCKING
Tighten CLEANING BOLT, UNION	90401-20008	BOLT, UNION	M20 x 1.5	70±10 (7.0±1.0)	1	Apply oil when tightening the case.

Engine

To be tightened	Part No.	Part Name	Thread dia. x pitch	Tightening torque N•m (kgf•m)	Q'ty	Remarks
Install OIL CLEANER ASSY	5GH-13440-50	OIL CLEANER ASSY	M20 x 1.5	17±2 (1.7±0.2)	1	APPLY GREASE TO O-RING.
Install OIL PAN BAFFLE	90110-06218	BOLT, HEXAGON SOCKET HEAD	M6 x 1.0	10±2 (1.0±0.2)	2	APPLY TO SCREW ROCKING
Install COVER, STRAINER	90109-06300	BOLT	M6 x 1.0	FOR DETAILS, SEE page 67. (List of tightening AL bolts)	12	STRAINER COVER
Tighten the main gallery side of OIL PIPE COMP.	90110-06395	BOLT, HEXAGON SOCKET HEAD	M6 x 1.0	10±2 (1.0±0.2)	1	APPLY TO SCREW ROCKING
Tighten together with OIL PIPE COMP.	90110-06389	BOLT, HEXAGON SOCKET HEAD	M6 x 1.0	10±2 (1.0±0.2)	2	APPLY TO SCREW ROCKING
Tighten the cover side of OIL PIPE COMP.2	90110-06295	BOLT, HEXAGON SOCKET HEAD	M6 x 1.0	10±2 (1.0±0.2)	1	APPLY TO SCREW ROCKING
Install OIL HOSE	90110-06211	BOLT, HEXAGON SOCKET HEAD	M6 x 1.0	10±2 (1.0±0.2)	4	APPLY TO SCREW ROCKING
Install OIL COOLER STAY	90110-06341	BOLT, HEXAGON SOCKET HEAD	M6 x 1.0	10±2 (1.0±0.2)	3	
Install the upper side of the OIL COOLER	90110-06346	BOLT, HEXAGON SOCKET HEAD	M6 x 1.0	10±2 (1.0±0.2)	2	
Install the lower of the OIL COOLER	95827-06030	BOLT, FLANGE	M6 x 1.0	10±2 (1.0±0.2)	1	
Install THROTTLE WIRE	2CR-26302-00	BOLT, ADJUSTING	M6	3.5 – 5.5 (0.35 – 0.55)	2	
JOINT ASSY x THROTTLE BODY	90450-60004	HOSE CLAMP	M5 x 0.8	3±0.5 (0.3±0.05)	4	Collar striking or torque management
THROTTLE x FUNNEL	90110-06163	BOLT	M6 x 1.0	8±2 (0.8±0.2)	6	

Engine

To be tightened	Part No.	Part Name	Thread dia. x pitch	Tightening torque N•m (kgf•m)	Q'ty	Remarks
UPPER COVER	98907-05020	SCREW, BINDING HEAD	M5 x 0.8	2.0±0.5 (0.2±0.05)	10	(TARGET VALUE OF 2.0 N•m)
NUT, RING x CYLINDER HEAD	90179-08442	NUT	M8 x 1.25	20±2 (2.0±0.2)	8	
EX. PIPE x CHAMBER	95024-08035	BOLT, FLANGE (SMALL HEAD)	M8 x 1.25	20±2 (2.0±0.2)	2	
CHAMBER x STAY MUFFLER	90109-08238	BOLT	M8 x 1.25	20±2 (2.0±0.2)	2	
CHAMBER x SIDE STAND	90110-08099	BOLT, HEXAGON SOCKET	M8 x 1.25	20±2 (2.0±0.2)	1	
CHAMBER x SILENCER	90110-06343	BOLT, HEXAGON SOCKET	M6 x 1.0	10±2 (1.0±0.2)	1	
SILENCER x STAY MUFFLER3	90110-08071	BOLT, HEXAGON SOCKET	M8 x 1.25	20±2 (2.0±0.2)	1	
Install WIRE PULLEY DOUBLE NUT	2CR-1133E-□□ 2CR-1133F-□□	WIRE, PULLEY,1 WIRE, PULLEY,2	M6 x 1.0	5 – 7 (0.5 – 0.7)	2	
Install SERVOMOTOR	90110-06106	BOLT, HEXAGON SOCKET	M6 x 1.0	10±2 (1.0±0.2)	1	
CHAMBER x PROTECTOR ASSY.	90111-06153	BOLT, HEXAGON SOCKET BUTTON	M6 x 1.0	10±2 (1.0±0.2)	3	
OIL PATHWAY THROTTLING NOZZLE	2CR-15138-00	NOZZLE	M8 x 1.25	2.5 – 3.5 (0.25 – 0.35)	5	Control by ad- ditional tightening method
CRANKCASE 1 x CRANKCASE 2	90119-09010	BOLT, HEXAGON WITH WASHER	M9 x 1.25	FOR DETAILS, SEE page 66. (Installing the Crank- case)	10	Apply oil to the thread part and bearing surface. Do not reuse a mended part.
CRANKCASE 1 x CRANKCASE 2	14B-15156-00	BOLT, CRANK- CASE JOURNAL	M8 x 1.25	24±2 (2.4±0.2)	8	Apply oil to the thread part, bear- ing surface and O-RING part. Do not reuse a mended O-RING.

Engine

To be tightened	Part No.	Part Name	Thread dia. x pitch	Tightening torque N•m (kgf•m)	Q'ty	Remarks
CRANKCASE 1 x CRANKCASE 2	95812-08060	BOLT, FLANGE	M8 x 1.25	24±2 (2.4±0.2)	2	APPLY OIL TO BOTH SCREW THREAD AND BEARING.
CRANKCASE 1 x CRANKCASE 2	90109-06100	BOLT	M6 x 1.0	10±2 (1.0±0.2)	2	APPLY OIL TO BOTH SCREW THREAD AND BEARING.
CRANKCASE 1 x CRANKCASE 2	95812-06070	BOLT, FLANGE	M6 x 1.0	10±2 (1.0±0.2)	1	APPLY OIL TO BOTH SCREW THREAD AND BEARING.
CRANKCASE 1 x CRANKCASE 2	95812-06060	BOLT, FLANGE	M6 x 1.0	10±2 (1.0±0.2)	6	APPLY OIL TO BOTH SCREW THREAD AND BEARING.
CRANKCASE 1 x CRANKCASE 2	95812-06050	BOLT, FLANGE	M6 x 1.0	10±2 (1.0±0.2)	4	APPLY OIL TO BOTH SCREW THREAD AND BEARING.
CRANKCASE 1 x CRANKCASE 2	90105-06213	BOLT	M6 x 1.0	10±2 (1.0±0.2)	2	APPLY TO SCREW ROCKING. APPLY OIL TO THE BEARING SURFACE ONLY.
CRANKCASE 1 x CRANKCASE 2	95812-06040	BOLT, FLANGE	M6 x 1.0	10±2 (1.0±0.2)	5	APPLY OIL TO BOTH SCREW THREAD AND BEARING.
Install NOZZLE ASSY. (15105)	90149-06158	SCREW	M6 x 1.0	10±2 (1.0±0.2)	4	APPLY TO SCREW ROCKING
Install COVER CRANK CASE 1 (15411)	90109-06300	BOLT	M6 x 1.0	FOR DETAILS, SEE page 67. (List of tightening AL bolts)	8	ACM COVER
Install COVER CHAIN CASE (15418)	90110-06387	BOLT, HEXAGON SOCKET HEAD	M6 x 1.0	10±2 (1.0±0.2)	3	DRIVE SPROCKET COVER
Install COVER CRANK CASE 2 (15421)	90109-06301	BOLT	M6 x 1.0	FOR DETAILS, SEE page 67. (List of tightening AL bolts)	10	CLUTCH COVER
Install COVER 1 (15416)	90109-06299	BOLT	M6 x 1.0	FOR DETAILS, SEE page 67. (List of tightening AL bolts)	5	CAM CHAIN COVER
Install COVER (15413)	90109-06300	BOLT	M6 x 1.0	FOR DETAILS, SEE page 67. (List of tightening AL bolts)	8	BREATHER COVER

Engine

To be tightened	Part No.	Part Name	Thread dia. x pitch	Tightening torque N•m (kgf•m)	Q'ty	Remarks
Install PLATE, BREATHER	90149-06158	SCREW	M6 x 1.0	10±2 (1.0±0.2)	4	APPLY TO SCREW ROCKING
Install PLUG to COVER CRANK CASE 1	90340-27003	PLUG, STRAIGHT SCREW	M27 x 1.5	15±2 (1.5±0.2)	1	FOR CRANK ROTATION
Install COVER CRANK CASE 1	90109-08239	BOLT	M8 x 1.25	15±2 (1.5±0.2)	1	CHECK TIMING.
Install PLUG to COVER CRANK CASE 2	2CR-15363-01	PLUG, OIL	M20 x 1.5	Attached firmly to the bearing surface.	1	
Install DAMPER to COVER CRANK CASE 2	90149-06158	SCREW	M6 x 1.0	10±2 (1.0±0.2)	4	APPLY TO SCREW ROCKING
PLUG for REAR PATHWAY of OIL FILTER	4H7-15189-00	PLUG	M20 x 1.5	8±2 (0.8±0.2)	2	TAKE CARE NOT TO OVERTIGHTEN.
Install CLUTCH WIRE HOLDER	90110-06340	BOLT	M6 x 1.0	10±2 (1.0±0.2)	2	APPLY TO SCREW ROCKING
ACM LEAD	90110-06182	BOLT, HEXAGON SOCKET HEAD	M6 x 1.0	10±2 (1.0±0.2)	1	APPLY TO SCREW ROCKING
Install STATOR	90149-06128	SCREW	M6 x 1.0	10±2 (1.0±0.2)	3	APPLY TO SCREW ROCKING. TORQUES
Install PLUG (2CR-15189-00-1)	90110-06396	BOLT, HEXAGON SOCKET	M6 x 1.0	10±2 (1.0±0.2)	2	
Install JOINT (15319)	90149-06068	SCREW	M6 x 1.0	10±2 (1.0±0.2)	1	TAKE CARE NOT TO OVERTIGHTEN. FOR HYDRAU- LIC SENSOR.
Install PLATE (15113)	90110-06108	BOLT, HEXAGON SOCKET	M6 x 1.0	12±2 (1.2±0.2)	4	APPLY TO SCREW ROCKING
Install IDLER SHAFT	90110-06401	BOLT, HEXAGON SOCKET	M6 x 1.0	10±2 (1.0±0.2)	1	APPLY TO SCREW ROCKING
Install STARTER ONE-WAY OUTER	90149-06158	SCREW	M6 x 1.0	14±2 (1.4±0.2)	3	APPLY TO SCREW ROCKING

Engine

To be tightened	Part No.	Part Name	Thread dia. x pitch	Tightening torque N•m (kgf•m)	Q'ty	Remarks
Install CLUTCH BOSS	90179-20007	NUT	M20 x 1.0	125±5 (12.5±0.5)	1	APPLY OIL TO BOTH SCREW THREAD AND BEARING. 1 POINT SWAGING AFTER TIGHTENING
Install CLUTCH SPRING	2CR-16337-00	SCREW, SPRING1	M6 x 1.0	10±2 (1.0±0.2)	3	
Install BEARING HOUSING	90149-06082	SCREW	M6 x 1.0	12±2 (1.2±0.2)	3	APPLY TO SCREW ROCKING
Tighten DRIVE SPROCKET	90179-22018	NUT	M22x 1.0	125±10 (12.5±1.0)	1	2 POINT SWAGING AFTER TIGHTENING
Install STOPPER, SHIFT BAR and PLATE, STOPPER 2	90149-06158	SCREW	M6 x 1.0	10±2 (1.0±0.2)	2	APPLY TO SCREW ROCKING
Install STOPPER SCREW	1D7-18127-00	STOPPER, SCREW	M8 x 1.25	22±2 (2.2±0.2)	1	APPLY TO SCREW ROCKING
Install ARM, SHIFT	90105-06127	BOLT, FLANGE	M6 x 1.0	10±2 (1.0±0.2)	1	CHECK SERRATION FOR TIGHTENING UP
Install SENSOR, GEAR POSITION	90110-05067	BOLT, HEXAGON SOCKET	M5 x 0.8	3 – 5 (0.3 – 0.5)	2	APPLY TO SCREW ROCKING
Install NEUTRAL SWITCH	3GB-82540-01	NEUTRAL SWITCH ASSY.	M10 x 1.25	17±3 (1.7±0.3)	1	OVERTIGHTENING MAY DAMAGE THE PART
Install COVER, SERVOMOTOR	97702-50514	SCREW, TRUSS HEAD TAP- PING	M5	1 – 3 (0.1 – 0.3)	2	
Install THERMO SENSOR (for water temperature)	4P9-83591-00	THERMO SENSOR ASSY	M10 x 1.25	16±2 (1.6±0.2)	1	
SENSOR, CAM POSITION	90110-06175	BOLT, HEXAGON SOCKET HEAD	M6 x 1.0	7.5±1.5 (0.75±0.15)	1	APPLY TO SCREW ROCKING

Engine

To be tightened	Part No.	Part Name	Thread dia. x pitch	Tightening torque N•m (kgf•m)	Q'ty	Remarks
Install PICKUP ASSY	90110-05034	BOLT, HEXAGON SOCKET HEAD	M5 x 0.8	6±1 (0.6±0.1)	2	APPLY TO SCREW ROCKING
OIL PRESSURE SWITCH	1WS-82504-00	SW. OIL PRESSURE	PT1/8	12.5±2 (1.25±0.2)	1	When mended, use 67F-82504-0 and apply the sealing agent to the thread part ThreeBond MEC #2403
Install OIL PRES- SURE SWITCH LEAD WIRE	WS-82504-00 accessory	BOLT	M4 x 0.7	1.5 – 2.0 (0.15 – 0.2)	1	
Install STARTER MOTOR	91312-06030	BOLT, HEXAGON SOCKET HEAD	M6 x 1.0	10±2 (1.0±0.2)	2	

BX4 SERIES

To be tightened	Part No.	Part Name	Thread dia. x pitch	Tightening torque N•m (kgf•m)	Q'ty	Remarks
Install COVER, STRAINER	BX4-13573-00	BOLT	M6 x 1.0	FOR DETAILS, SEE page 67. (List of tightening AL bolts)	2	STRAINER COVER
Install COVER CRANK CASE 2 (15421)	90109-06301	BOLT	M6 x 1.0	FOR DETAILS, SEE page 67. (List of tightening AL bolts)	10	CLUTCH COVER
Install CLUTCH WIRE HOLDER	90110-06399	BOLT	M6 x 1.0	10±2 (1.0±0.2)	2	APPLY TO SCREW ROCKING

Chassis

To be tightened	Part No.	Part Name	Thread dia. x pitch	Tightening torque N•m (kgf•m)	Q'ty	Remarks
E/G BRACKET, FRONT, LEFT	90110-12007	BOLT, HEXAGON SOCKET	M12 x 1.25	64 – 76 (6.4 – 7.6)	1	PROCEDURE TO INSTALL THE ENGINE. FOR DETAILS, SEE page 69.
E/G BRACKET, FRONT, RIGHT	90111-12003	BOLT, HEXAGON SOCKET BUTTON	M12 x 1.25	64 – 76 (6.4 – 7.6)	1	PROCEDURE TO INSTALL THE ENGINE. FOR DETAILS, SEE page 69.
E/G BRACKET, REAR UPPER	90110-12008	BOLT, HEXAGON SOCKET	M12 x 1.25	50 – 62 (5.0 – 6.2)	1	PROCEDURE TO INSTALL THE ENGINE. FOR DETAILS, SEE page 69.
	90179-12004	NUT				
E/G BRACKET, REAR UNDER	90110-12010	BOLT, HEXAGON SOCKET	M12 x 1.25	50 – 62 (5.0 – 6.2)	1	PROCEDURE TO INSTALL THE ENGINE. FOR DETAILS, SEE page 69.
	90179-12004	NUT				
ADJUST BOLT for E/G BRACKET, REAR	5YU-21495-00	BOLT, ENGINE ADJUSTING	M18 x 1.0	7 – 9 (0.7 – 0.9)	2	PROCEDURE TO INSTALL THE ENGINE.. FOR DETAILS, SEE page 69. Apply grease or engine oil (10W- 30 or 20W-40 equivalent) and tighten it. Be sure to tighten at the nut side.
STAY and FRAME on the front side of the tank			M6 x 1.0	7 – 10 (0.7 – 1.0)	1	
MAIN FRAME & REAR FRAME	90149-10002	SCREW	M10 x 1.25	33 – 40 (3.3 – 4.0)	4	
SHAFT, PIVOT & FRAME	14B-22141-00	SHAFT, PIVOT	M30 x 1.0	5 – 8 (0.5 – 0.8)	1	PROCEDURE TO INSTALL THE PIVOT SHAFT PERIPHERAL PARTS. FOR DETAILS, SEE page 70.
SHAFT, PIVOT & LOCK NUT	4C8-22252-00	NUT, 2	M30 x 1.0	50 – 80 (5.0 – 8.0)	1	PROCEDURE TO INSTALL THE PIVOT SHAFT PERIPHERAL PARTS. FOR DETAILS, SEE page 70.

Chassis

To be tightened	Part No.	Part Name	Thread dia. x pitch	Tightening torque N•m (kgf•m)	Q'ty	Remarks
SHAFT, PIVOT & U NUT	90185-20008	NUT, SELF LOCKING	M20 x 1.5	80 – 130 (8.0 – 13.0)	1	PROCEDURE TO INSTALL THE PIVOT SHAFT PERIPHERAL PARTS. FOR DETAILS, SEE page 70.
ARM RELAY and FRAME	90109-10017	BOLT	M10 x 1.25	31 – 49 (3.1 – 4.9)	1	
	95602-10200	NUT, U FLANGE				
ARM, RELAY & ARM	90109-12010	BOLT	M10 x 1.25	31 – 49 (3.1 – 4.9)	1	
	92902-12600	WASHER, PLAIN				
	90185-12011	NUT, SELF LOCKING				
ARM & REAR ARM	90109-12010	BOLT	M10 x 1.25	31 – 49 (3.1 – 4.9)	1	
	92902-12600	WASHER, PLAIN				
	90185-12011	NUT, SELF LOCKING				
REAR CUSHION & ARM, RELAY	90105-10017	BOLT, FLANGE	M10 x 1.25	31 – 49 (3.1 – 4.9)	1	
	95602-10200	NUT, U FLANGE				
REAR CUSHION and FRAME	95602-10200	NUT, U FLANGE	M10 x 1.25	31 – 49 (3.1 – 4.9)	1	
	90105-10609	BOLT, FLANGE				
ADJUST NUT for CHAIN PULLER	90101-08013	BOLT, HEXAGON	M8 x 1.25	12 – 19 (1.2 – 1.9)	2	
	95302-08600	NUT, HEXAGON				
	90201-08057	WASHER, PLAIN				
HANDLE, CROWN & OUTER TUBE	91314-08030	BOLT, HEXAGON SOCKET HEAD	M8 x 1.25	23 – 28 (2.3 – 2.8)	2	
HANDLE, CROWN & STEERING SHAFT	90170-28419	NUT, HEXAGON	M28 x 1.0	100 – 125 (10.0 – 12.5)	1	
HANDLE & OUTER TUBE	91314-08025	BOLT, HEXAGON SOCKET HEAD	M8 x 1.25	28 – 35 (2.8 – 3.5)	2	

Chassis

To be tightened	Part No.	Part Name	Thread dia. x pitch	Tightening torque N•m (kgf•m)	Q'ty	Remarks
HANDLE and HANDLE, CROWN	91380-06025	BOLT, HEXAGON SOCKET HEAD	M6 x 1.0	5 – 8 (0.5 – 0.8)	2	
STEERING SHAFT and RING NUT	90179-30691	NUT	M30 x 1.0	40 – 64 (4.0 – 6.4)	1	
				12 – 15 (1.2 – 1.5)		
OUTER TUBE and UNDER BRACKET	91314-08030	BOLT, HEXAGON SOCKET HEAD	M8 x 1.25	20 – 25 x 2 (2.0 – 2.5 x 2)	4	
FUEL TANK & FUEL PUMP	90119-05015	BOLT, HEXAGON WITH WASHER	M5 x 0.8	3 – 5 (0.3 – 0.5)	4	
FRONT STAY for FUEL TANK & FUEL TANK	90110-06233	BOLT, HEXAGON SOCKET	M6 x 1.0	3 – 5 (0.3 – 0.5)	1	
REAR STAY for FUEL TANK & REAR FRAME	90111-06071	BOLT, HEXAGON SOCKET BUTTON	M6 x 1.0	5 – 8 (0.5 – 0.8)	4	
REAR STAY for FUEL TANK & FUEL TANK	95812-06090	BOLT, FLANGE	M6 x 1.0	3 – 5 (0.3 – 0.5)	1	
	95702-06500	NUT, FLANGE				
FRONT WHEEL SHAFT & NUT	90179-24004	NUT	M24 x ***	100 – 130 (10.0 – 13.0)	1	
REAR WHEEL SHAFT & NUT	90185-24007	NUT, SELF LOCKING	M24 x 1.5	160 – 220 (16.0 – 22.0)	1	
FRONT CALIPER & FRONT FORK	90105-10397	BOLT, FLANGE	M10 x 1.25	30 – 40 (3.0 – 4.0)	4	
DISC BRAKE & WHEEL (FRONT)	2CR-2589H-00	SCREW	M6 x 1.0	14 – 19 (1.4 – 1.9)	10	
DISK BRAKE & PLATE DISK 1	90149-08009	SCREW	M8 x 1.25	23 – 37 (2.3 – 3.7)	5	
REAR WHEEL SPROCKET & CLUTCH HUB	90185-10011	NUT, SELF LOCKING	M10 x 1.25	90 – 109 (9.0 – 10.9)	5	
SPLIT BOLT for FRONT AXLE	91314-08040	BOLT, HEXAGON SOCKET HEAD	M8 x 1.25	18 – 23 (1.8 – 2.3)	4	

For reference

	Tightening torque N•m
M5 × 0.8	4.5 – 7.0
M6 × 1.0	7.5 – 12
M8 × 1.25	18 – 28
M10 × 1.25	37 – 58
M12 × 1.25	68 – 108
M14 × 1.5	105 – 167

Tightening the Cylinder Head

1. In the following order (1→10), apply initial tightening of 10 N•m (1.0 kgf•m).
2. In the following order (1→10), apply additional tightening of 25 N•m (2.5 kgf•m).
3. In the following order (1→10), apply additional tightening of 45 N•m (4.5 kgf•m).
4. In the following order (1→10), loosen each bolt. Then, tighten at 15 N•m (1.5 kgf•m) and tighten at rotating angle of 160°.

(Note: Do not loosen all bolts at once. Repeat loosening and tightening operation one by one bolt.)

TIP

The numbers 1 to 10 show the sequence in which the bolts are tightened.

Apply engine oil to the bearing surface and thread part of the bolt.

Use a new bolt only. (Do not reuse)

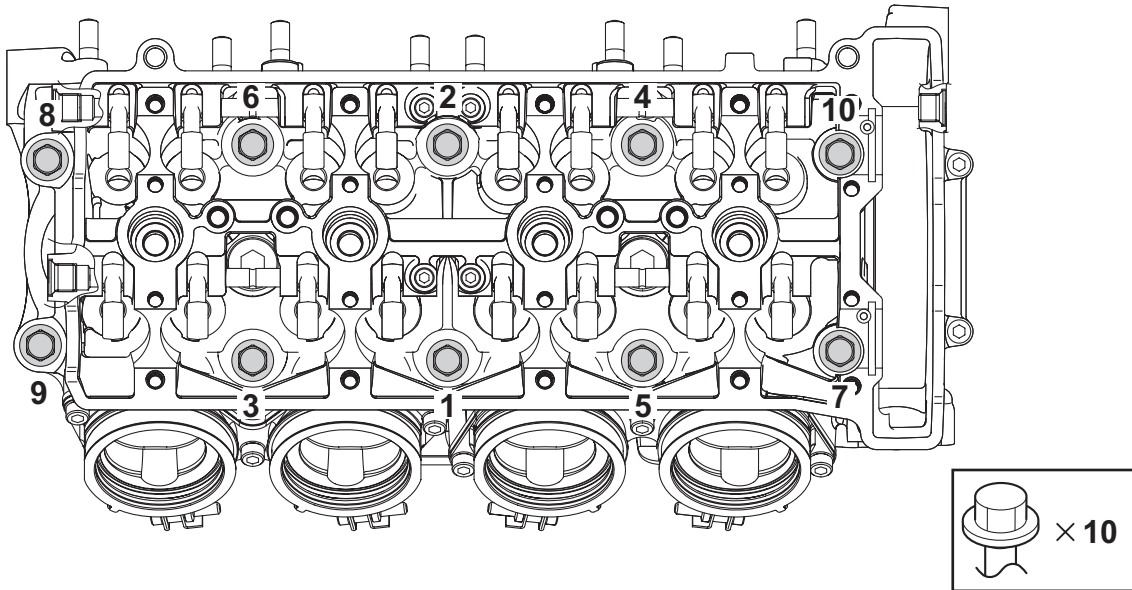

Installing the Crankcase

1. Tighten the bolts in the tightening sequence of 1 to 10 to 20 N•m (2.0 kg•m).
2. After loosening the bolts once in the tightening sequence of 1 to 10, retighten them one by one to 15 N•m (1.5 kg•m).
(Note: Do not loosen all bolts at once. Repeat loosening and tightening operation one by one bolt.)
3. Retighten the bolts in the tightening sequence of 1 to 10 to a turn-of-nut angle of $75^{\circ}\pm 5^{\circ}$.
4. Tighten the bolts in the tightening sequence of 11 to 20 to 24 ± 2 N•m (2.4 ± 0.2 kgf•m).
5. Tighten the bolts in the tightening sequence of 21 to 40 to 10 ± 2 N•m (1.0 ± 0.2 kgf•m).

TIP

The numbers 1 to 40 show the sequence in which the bolts are tightened.

Apply engine oil to the bolts 1 to 10, 21 to 27 and 29 to 39, and the both sides of the washer. Apply screw rock agent to the bolts 28 and 40 (apply engine oil to the bearing surface only). Apply oil to the thread part, bearing surface and O-RING part of the bolts 11 to 20. Do not reuse a mended O-RING.

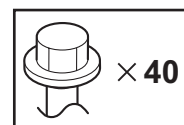
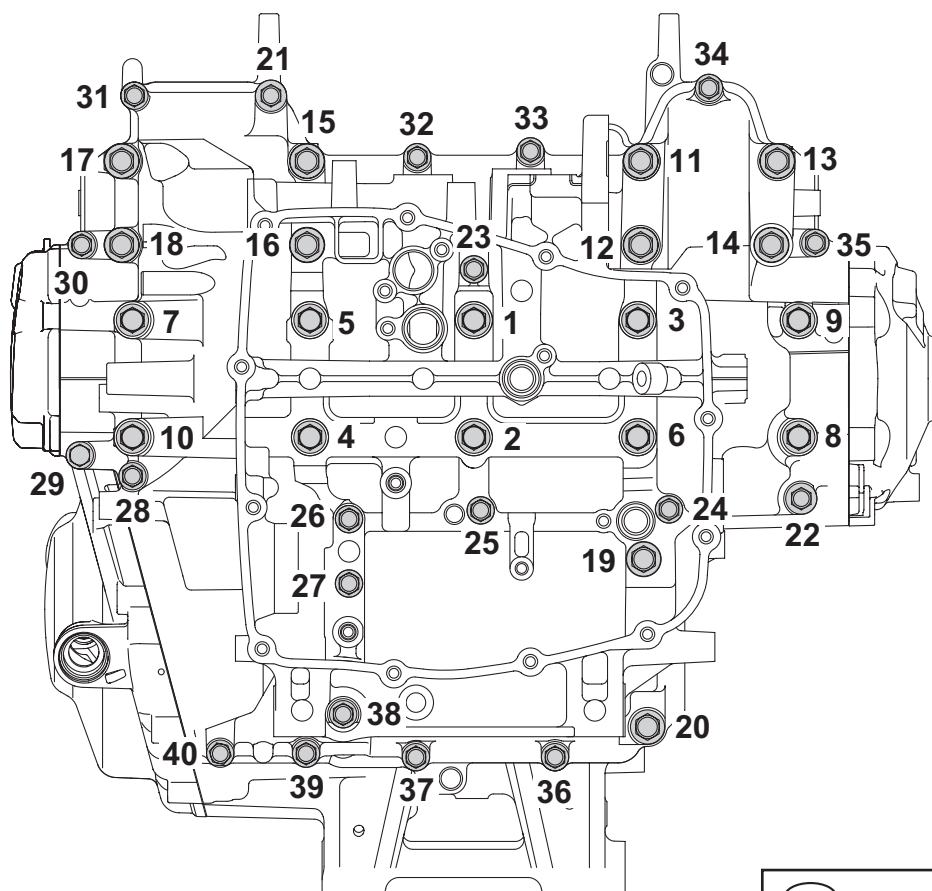

Procedure to tighten the aluminum bolts

1. In the following order, tighten the bolt at $6\text{N}\cdot\text{m}$ ($0.6\text{kgf}\cdot\text{m}$).
2. In the following order, loosen each bolt, tighten at $3\text{N}\cdot\text{m}$ ($0.3\text{kgf}\cdot\text{m}$), and apply snap and angle tightening at rotating angle of 90° .

(Note: Do not loosen all bolts at once. Repeat loosening and tightening operation one by one bolt.)

TIP

The numbers 1 to 12 show the sequence in which the bolts are tightened. Use a new bolt only. (Do not reuse)

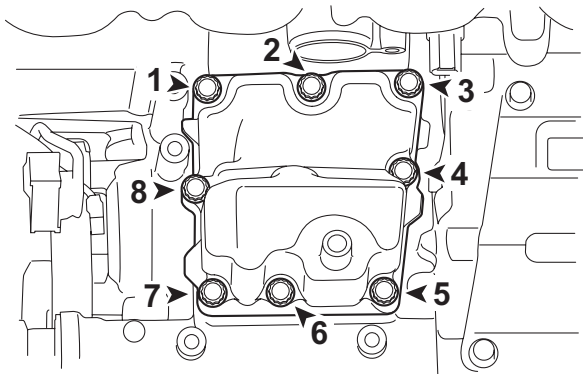
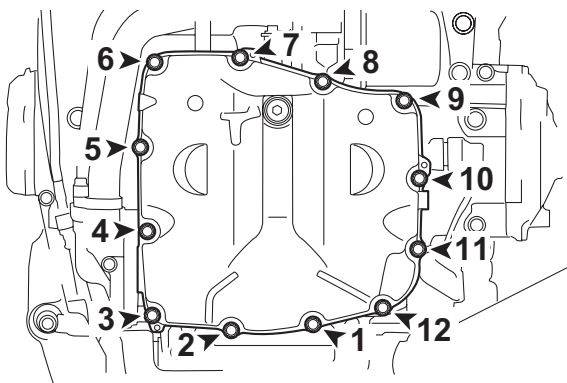
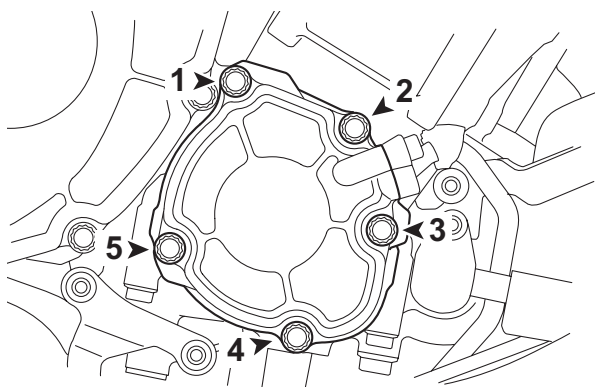
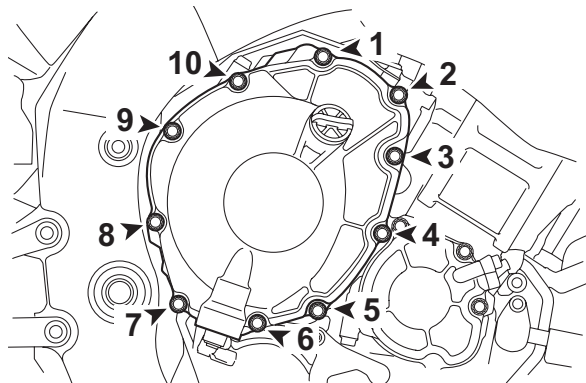
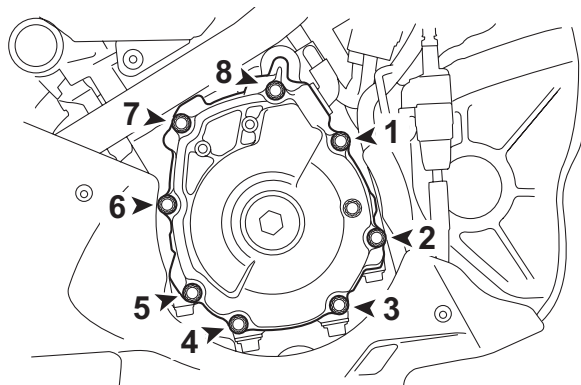

When replacing aluminum bolts with iron bolts

Use the following table as a reference when replacing aluminum bolts with iron bolts.

To be tightened	Part No.	Part Name	Thread dia. x pitch	Tightening torque N•m (kgf•m)	Q'ty	Remarks
Install COVER, STRAINER	90110-06390	BOLT, HEXAGON SOCKET	M6 x 1.0	12±2 (1.2±0.2)	12	APPLY TO SCREW ROCKING STRAINER COVER
Install COVER CRANK CASE 1 (15411)	90110-06387	BOLT, HEXAGON SOCKET	M6 x 1.0	12±2 (1.2±0.2)	8	ACM COVER
Install COVER CRANK CASE 2 (15421)	90110-06388	BOLT, HEXAGON SOCKET	M6 x 1.0	12±2 (1.2±0.2)	10	CLUTCH COVER
Install COVER 1 (15416)	90110-06396	BOLT, HEXAGON SOCKET	M6 x 1.0	12±2 (1.2±0.2)	5	CAM CHAIN COVER
Install COVER (15413)	90110-06387	BOLT, HEXAGON SOCKET	M6 x 1.0	12±2 (1.2±0.2)	8	BREATHER COVER

Procedure to install the engine (unchangeable)

1. Attach the two engine adjusting bolts 1 to the frame COMP. temporarily.
2. Fit the engine installation position to the frame COMP and attach the bolts 2 and 3 temporarily.
3. Attach the bolt 4 temporarily.
4. Attach the engine mount boss 5 and 6 to the frame COMP. temporarily and then attach the bolt 7 temporarily.
5. Tighten the two engine adjusting bolts 1 at specified torque.

Check that the bearing surface of the bolts 1 completely fit the surface of the engine.

6. Tighten the two nuts 8 and 9 at specified torque. Tighten the nut 8 (lower side) at first, then tighten the nut 9 (upper side).
7. Tighten the bolt 4 at specified torque.
8. Tighten the bolt 7 at specified torque.

TIP

For information about tightening torque and requirement for lubricant agent, see the list of tightening torque.

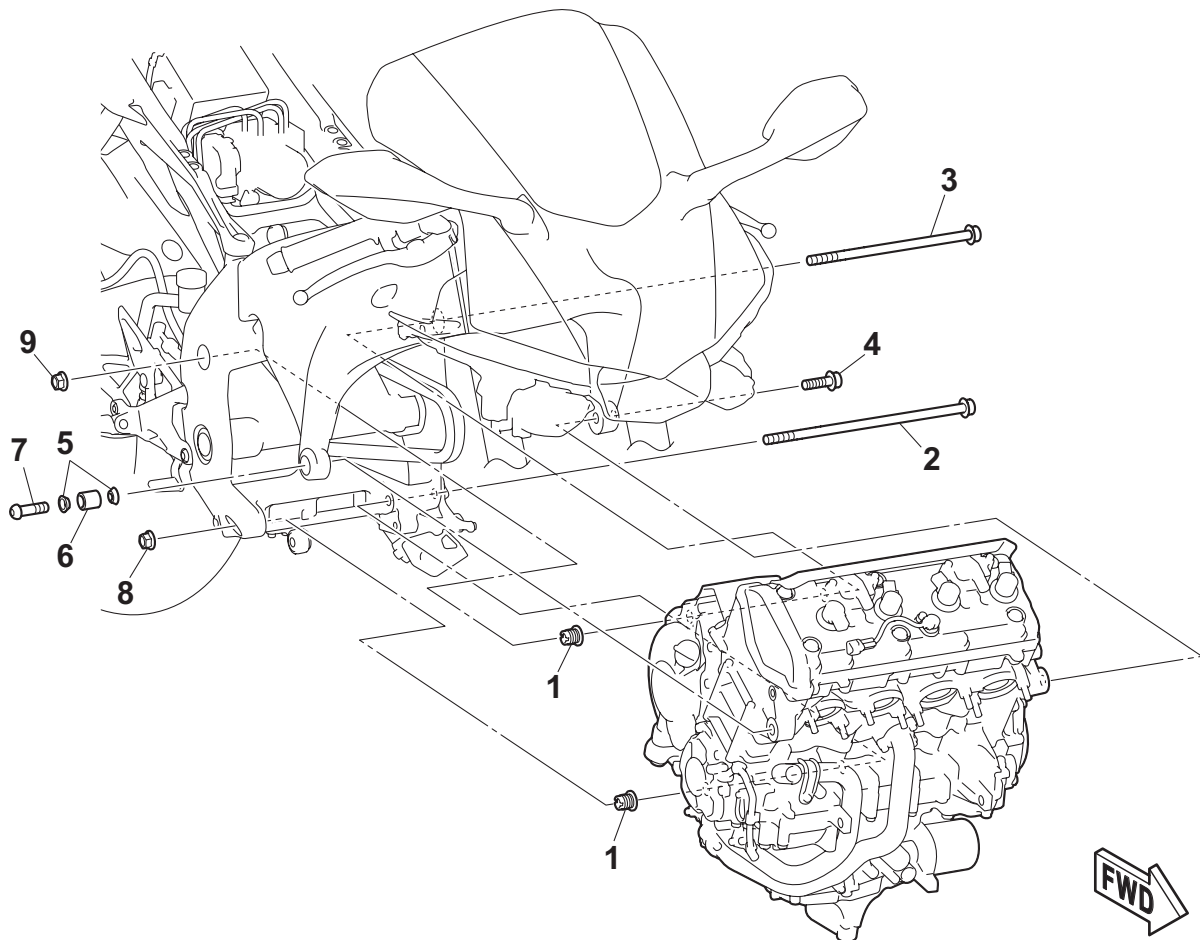

Procedure to install the pivot shaft peripheral parts

1. Tighten the pivot shaft 1 at specified torque.
2. Tighten the nut 2 at specified torque.
3. Tighten the nut 3 (self-rocking) at specified torque.

Be sure to secure the pivot shaft 1 so that it is not co-rotated.

TIP

For information about tightening torque and requirement for lubricant agent, see the list of tightening torque.

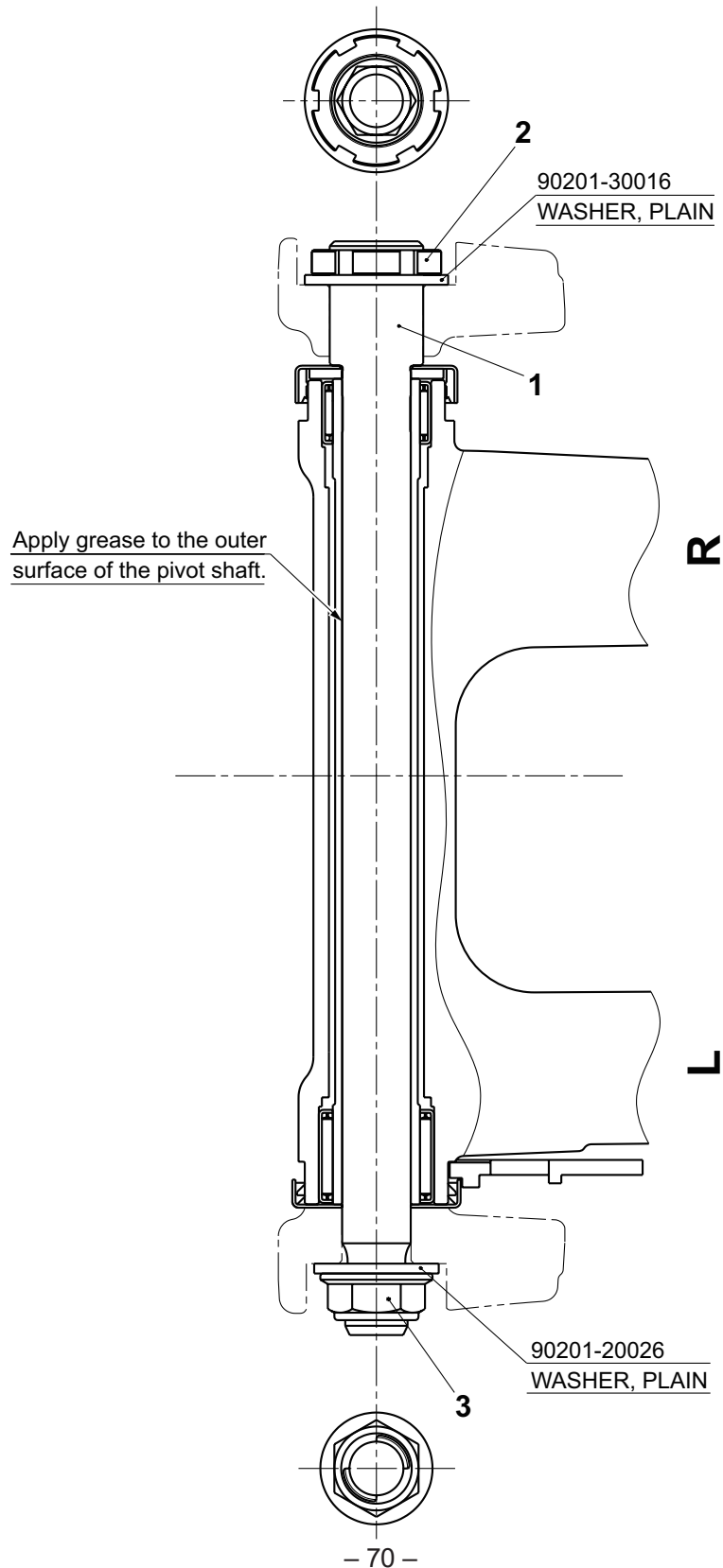

4 Headlight Cord Wiring Diagram

- 71 -

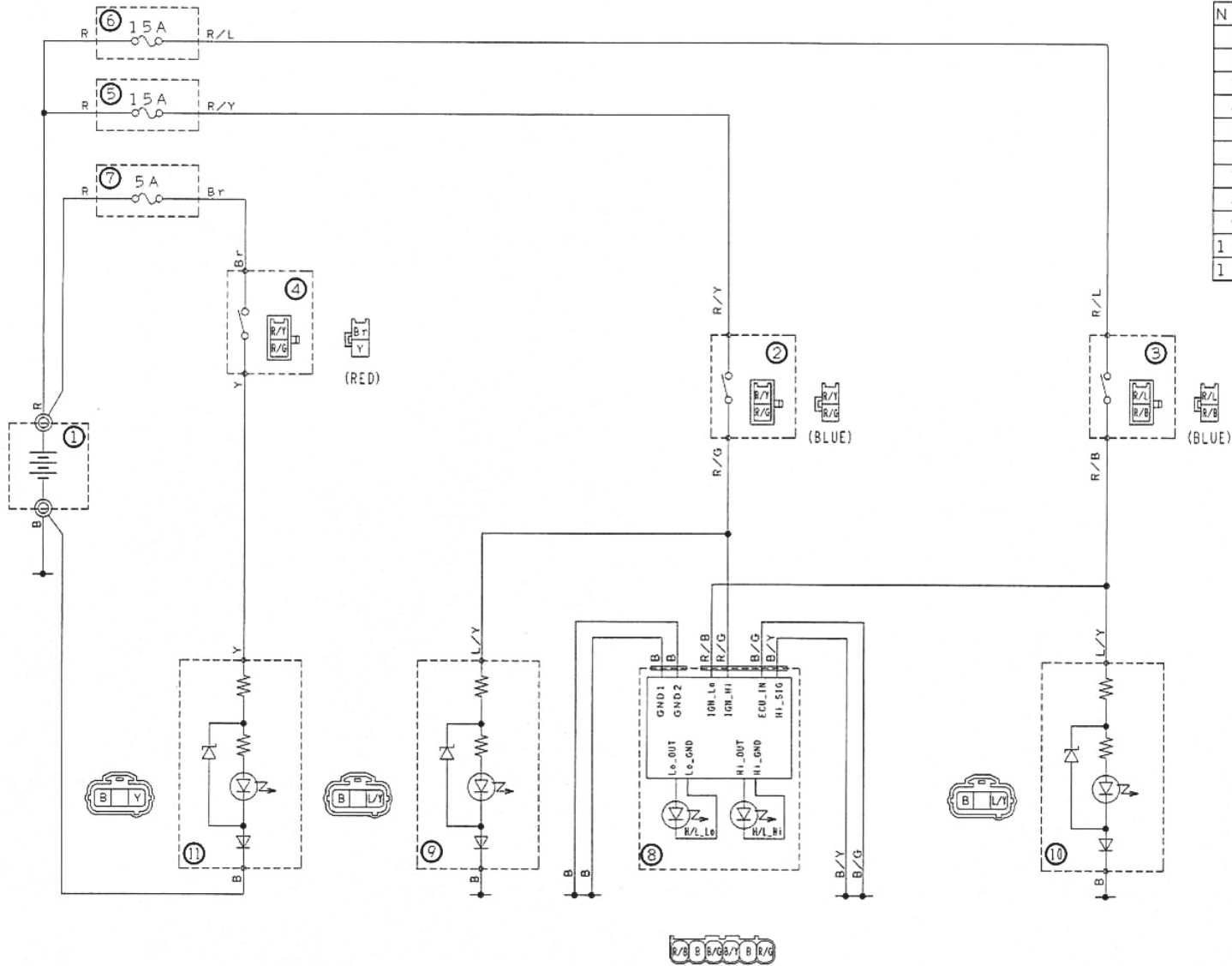

No.	COMPONENTS
1	BTRY.
2	SW. HANDLE 1
3	SW. HANDLE 2
4	EMERGENCY SW.
5	FUSE 1 (15A)
6	FUSE 2 (15A)
7	FUSE 3 (5A)
8	HEAD LIGHT
9	TAIL LIGHT 1 (Hi-side)
10	TAIL LIGHT 2 (Low-side)
11	EMERGENCY LIGHT

5 YZF-R1 Wiring Diagram

